



# Electric Chain Hoists

Compact, Heavy Duty, Competitively Priced

Japanese Technology  
Load limited  
Thermal overload prevention  
Emergency Stop button

TECH-RP Optional remote control unit available, suits below models only  
The remote control distance (no shielding) is 70m.



IP Rating  
Remote Control: IP55



IP Rating  
Hoist: IP54  
Control: IP65

## Electric Chain Hoists Single Phase

- Load Limited
- Thermal overload prevention
- Lightweight, compact design with high efficiency motor
- Pressed steel structure, high strength body
- High tensile alloy steel top & bottom hooks
- Grade 80 - 7.1mm Alloy Steel load chain
- Limit switches fitted at top and bottom ends to prevent chain runout
- 240V, 50Hz Single speed Motor 1200 Watts.
- \* Hoists can be re-chained to your required length (limits apply)
- Optional TECH-RP Remote Pendant Control to suit TOHO Single Phase Electric Chain Hoist (Must be fitted, there is a 1.5hrs Labour Charge)
- Complies with ASNZS 1418.2 standard

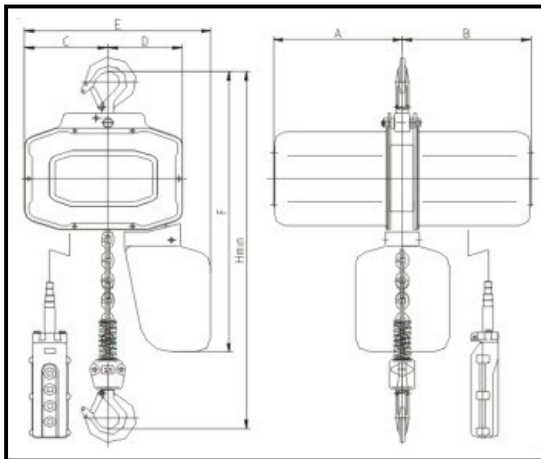

Models	TECH0103 TECH0106	TECH0203 TECH0206
Dimension (mm)		
A	245	245
B	245	245
C	158	124
D	142	176
E	350	350
F	600	610
H	520	630

1-phase, 240v, 50Hz (single speed)									
Model	Capacity ton	Standard Lift M	Running Test Load kN	Motor Power (kW)	No. of Chain	Dia of Chain mm	Lifting Speed (m/min)	Net Weight kg	Extra weight per metre of extra lift kg
TECH0103	1	3	12.5	1.2	1	7.1	6	60	1.1
TECH0106	1	6	12.5	1.2	1	7.1	6	63	1.1
TECH0203	2	3	25	1.2	2	7.1	3	65	2.2
TECH0206	2	6	25	1.2	2	7.1	3	71	2.2
TECH-RP	Remote Pendant Control to suit TOHO Single Phase Electric Chain Hoist (Must be fitted, there is a 1.5hrs Labour Charge)								



email: sales@garrickherbert.com.au  
Phone: 02 9545 6633  
web: www.garrickherbert.com.au