

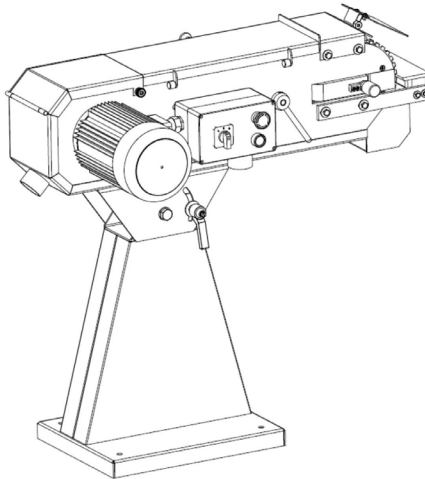

HEAVY DUTY LINISHER

MODEL - 2000/150/P3

USER'S OPERATING MANUAL & SERVICE INSTRUCTIONS



CAUTION

Read instruction manual before operating this machinery



460 - 462 The Boulevard, Kirrawee, NSW 2232

(P) (02) 9545-6633 (E) sales@garrickherbert.com.au

garrickherbert.com.au

FOREWORD

These instructions have been created by the manufacturer and are an integral part of the machine operations and safety. They contain basic information for qualified staff operating the machine and describe the environment and manners of the machine use for which it has been designed, and also contain any information necessary for the correct and safe operation.

The machine is equipped with various safety devices protecting both the operator and the machine for its common technological use. Nevertheless, these measures cannot cover all safety aspects and therefore it is necessary that the operator should read and understand these instructions before starting to use the machine. Errors made in the course of installation as well as during operation itself will thus be avoided.

Do not try therefore to put the machine into operation before you have read all instructions supplied and understood all its functions and working procedures.

Certain information or drawings may not be intended directly for the machine purchased by you as these instructions contain any information for various variants of this type made by our company. By comparing the respective part of the instructions with a particular machine you will find out whether or not they correspond to each other.

The manufacturer reserves the right to make partial alterations within continuous technical machine development.

USE OF THE MACHINE

Purpose of the machine

Metal belt sanders are mainly used to conduct surface polishing and grinding of metal and non-metal parts, to enhance the roughness and glossiness of spare parts surface. The machine performance is very efficient for grinding. It is an ideal substitute for polishing machines.

The machine must not be handled by children or inexperienced persons.

Workers qualifications

Only an expert, skilled in the field of metal-machining or a worker instructed and trained by such expert may operate the machine. While working on the machine the operator must be familiar with these instructions and comply with any safety rules, regulations and provisions in force in the respective country.

Working environment

The machine must be operated in a workshop environment,
Temperature MUST not exceed +40°C and does not drop below +5°C.
The relative humidity of ambient is from 30% to 95%, non-condensing.
The height above the sea level is up to 1000m.

Storage and transportation temperature: -25~55°C

The environment classification

- Danger of inflammable dust fire.

SAFETY INSTRUCTIONS

General

This machine is equipped with various safety devices protecting both the operator and the machine. Nevertheless, this cannot cover all safety aspects and therefore the operator, before putting the machine into operation. Furthermore, the operator must also take into account other aspects of danger relating to the surrounding conditions and material.

Basic safety requirements

- Before connecting the machine to the mains, make sure that all safety items are in their active positions and check their functioning. If it is necessary to remove the doors or protective covers, turn off the switch and disconnect the plug from its socket.
- Kick-back catchers must be freely movable and their functioning must be checked regularly, even several times a day.
- Do not connect the machine to the mains while the door or protective cover is removed.
- In order to avoid improper operation, get acquainted with the location of switches before switching the machine on.
- Remember the position (location) of the emergency stop switch so that you can use it promptly at any time.
- Be careful and do not touch any switches while the machine is being operated.
- Do not touch any rotating tool by hands or with any other object under any circumstances.
- In the case that you are not going to work on the machine, turn off the machine by the switch and disconnect the plug from the supply socket.
- Before cleaning the machine, switch off the machine and disconnect the plug of the machine.
- Before doing any maintenance work inside the machine, switch off the machine and disconnect the plug of the machine.
- Do not alter the machine in any manner which might cause any risk to safety and operation.
- If you have any doubts on the procedure, please contact a qualified professional for advice.
- Do not neglect performance of regular inspections in accordance with the instructions for use.
- Check and make sure that no disturbances occur on the machine caused by the user.
- After the work is finished, adjust the machine so that it is ready for another series of operations.
- Should a failure in power supply occur, switch off the machine immediately
- Do not paint, Dirty, cause any damage to, alter or remove safety plates. If they become illegible or lost, contact the manufacturer and replace the plates.
- Keep work area clear. Cluttered areas and benches cause injuries.
- Consider work area's environment. Do not expose tools to rain. Do not use tools in damp or wet location. Keep work area well lit. Do not use tools in the presence of flammable liquids or gases.

Clothes and personal safety

- Experience shows that injuries are caused by various personal articles, e.g. rings, watches, bracelets, bow tie etc. Therefore, take them off before starting to work, button the sleeves, take off a tie, which may be caught with various parts of the working machine. Wear hair protection and fasten hair properly to avoid catching by moving part. Wear suitable tight clothing, shoes recommended or prescribed by labour-safety regulations of all countries.
- Wear safety outfit (goggles, apron, safety shoes, hearing protection etc).
- In the case of any obstacles above your head – in the working area - wear a helmet.
- Always wear a protective mask while machining any material that produces dust while being used.
- Never wear any loose working clothes.
- Do not work on the machine under influence of drugs, alcohol, and or tiredness.

Safety regulations for operators

Do not put the machine into operation before you get acquainted with the contents of the instructions for use.

- Make sure that electric cables are not damaged so that injuries caused by electric current leaking (electric shocks) are avoided.
- Check regularly that safety covers are mounted properly and that they are not damaged. Repair damaged covers immediately or replace with other ones by a qualified person.
- Do not put the machine into operation with the cover removed.
- Never use any tools that are distorted, broken or blunt.
- Always use the tool suitable for the work given, which corresponds to the machine specifications. The tools, cutter blocks, must be in accordance with EN 847-1.
- Replace blunt tools as soon as possible, as blunt tools may cause injuries or damage.
- Never use the tools at speeds higher than their recommended rated speeds by the respective manufacturer.
- Stop all functions of the machines before replacing tools and pull out the plug from the supply socket.
- Do not remove or interfere otherwise in safety devices such as covers, limit switches.
- While handling parts that you are not familiar with, ask for help from a qualified person.
- It is not recommended to work on the machine during a storm.

Safety regulations for maintenance

Maintenance and repair must be performed by a qualified person.

Do not do any maintenance work before you get acquainted with these instructions and understood in detail.

- Before you start to perform any maintenance work, always turn off the switch and pull out the plug from supply socket. A possibility of accidentally putting the machine into operation by another person is thus avoided.
- Any maintenance work on electric parts of the equipment must be done by a qualified person only.
- Even if the machine is stopped, the power supply is not disconnected. Always disconnect the plug from supply socket.
- Do not clean the machine or its peripheral devices even if the machine is completely out of operation, unless the plug has been disconnected from supply socket. Keep your fingers at a distance from belts and belt pulleys.
- While replacing electrical parts of the equipment, turn off the switch and disconnect the plug from supply socket. Faulty parts should be replaced only with products having the same specifications as the original ones.
- Do not remove or interfere otherwise in safety devices such as covers, limit switches.
- Do not switch the machine on before all covers removed for the purposes of maintenance are put in their places again.
- Always keep the maintenance area including the working place clean.
- Any maintenance work must be done by a qualified staff in accordance with the instructions issued by the machine manufacturer.
- Read the instruction manual for maintenance carefully and completely.
- **For replacement of parts, only replace with the original type and that comply with standards.**
- Use only specified kinds or lubricating oils and grease or those equivalent to them.
- If any belt in the set of belts used gets longer than the limit prescribed, replace the whole set completely.
- Do not use compressed air to clean the machine or to remove chips.
- Always check the results while a responsible person is present.

Safety regulations for place of work

- Always ensure a sufficient working area and free access to the machine.
- Put tools and any other obstacles in the place designated for this purpose, in a distance from the machine.
- Ensure sufficient lighting in the working area which will not create shadows or cause the stroboscopic effect. For safe and quality work the hygienic standards specify the minimum intensity 500 lux.
- Never put any tools or any other objects on working tables or covers.
- Always keep the working area clean and tidy.

TRANSPORT AND STORAGE

While transporting or handling the machine, be most careful and let this activity be done by qualified person especially trained for this kind of activity.

While the machine is being loaded or unloaded, make sure that no person or object gets pressed by the machine!

Do not enter the area under the machine lifted by a crane or a high-lift trolley!

During transporting or storing the machine, means must be taken to protect the machine against excessive vibrations and humidity.

It should be stored in a shelter at temperatures ranging from -25°C to 55°C. As standard, the machine is wrapped up in a plastic tray and is transported this way. Machinery may be packed in a robust wooden box.

KNOW YOUR MACHINES

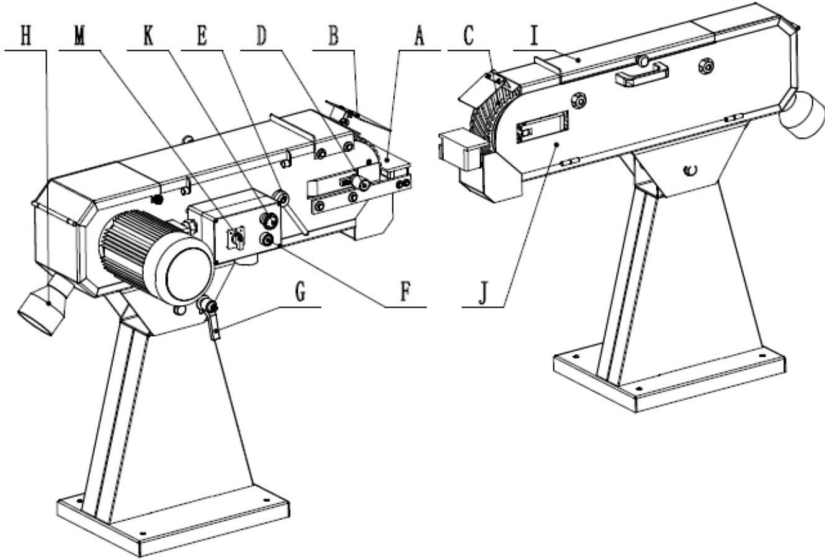

- | | |
|----------------------------------|-----------------------------|
| A. Spark Trap | G. Angle Adjustment Lever |
| B. Eye Shield | H. Dust Port |
| C. Contact Wheel | I. Belt Guards Long & Short |
| D. Belt Tracking Adjustment Knob | J. Cover Door |
| E. Belt Tension Release Lever | K. E-Stop Switch |
| F. Start Switch | M. Mode Selection Switch |

TECHNICAL SPECIFICATIONS

NAME	MSM75	MSM150	MSM75
Dimensions of sander (mm)	75 X 2000	150 X 2000	220 X 2000
Granularity of belt sander	80	80	80
Belt Linear velocity (m/s)	30(15)	30(15)	30(15)
Motor Speed (rpm)	2800 (1400)	2800 (1400)	2800 (1400)
Belt sanding table	460X75	460X150	460X220
Contact disc \varnothing / w	200/76	200/155	200/225

Specifications concerning noise of the device		
Level of noise A in the place of operation (LpAeq)	No-load	LpAeq =81.7 dB(A)
	Load	LpAeq =89.5 dB(A)
Level of acoustic power A (LWA)	No-load	LWA = 94.5 dB(A)
	Load	LWA = 103 dB(A)

**OPERATING CONDITIONS FOR NOISE MEASUREMENT
COMPLY WITH ANNEX B OF ISO 7960.**

The values given are those of emissions and do not necessarily mean any safe working values. Although there is a correlation between the value of emissions and the levels of exposure, these values cannot be used for reliable determination whether or not additional measures are necessary. The factors influencing actual levels of workers exposure include the properties of the working area, other sources of noise etc, E.g. The number of machines and the other neighboring procedures. Also the highest permissible levels of exposure may vary in different countries. This information should help the machine user to evaluate the risk and management.

WORKING CLEARANCES

Consider existing and anticipated needs, size of material to be processed through each machine, and space for auxiliary stands, work tables or other machinery when establishing a location for your new machine.

TEST RUN

Once the assembly is complete, test run your machine to make sure it runs properly. If, during the test run, you cannot easily locate the source of an unusual noise or vibration, stop using the machine immediately.

TO TEST RUN THE MACHINE:

1. Connect the machine to the power source.
2. Make sure you have read the safety instructions at the beginning of the manual and that the machine is setup properly.
3. Make sure all tools and objects used during set up are cleared away from the machine.
4. Turn the machine ON.
5. Listen to and watch for abnormal noises or actions. The machine should run smoothly with little or no vibration or rubbing noises.

NOTE: Strange or unusual noises should be investigated and corrected before operating the machine further. Always disconnect the machine from power when investigating or correcting potential problems.

ANGLE ADJUSTMENT

The sander can be angled up and down to meet your needs. Use the angle adjustment lever to lock the sander in the angle you choose. Tighten securely so the sander will not move during operation.

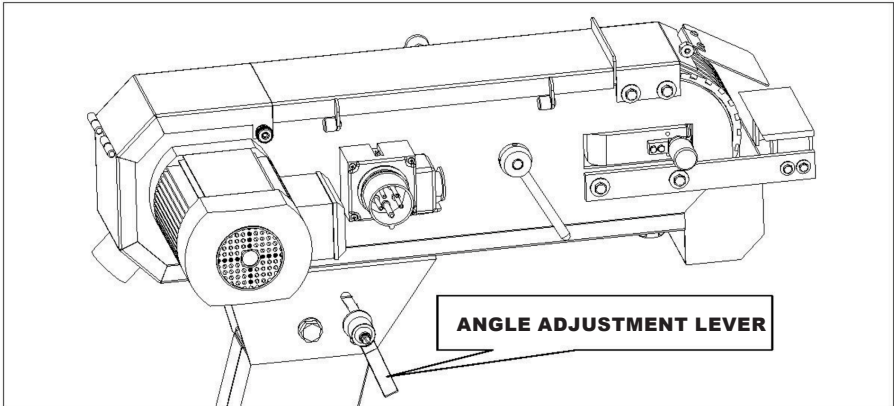

GRINDING TIPS

When grinding against the contact wheel, make sure the belt guard is closed.
Hold work piece securely with both hands.
Use the rests when possible to support the work piece.

The work piece will get hot as you continue to grind.

Cool the work piece frequently by placing in water or another approved solution.

Change belts frequently for the best performance.

Do not force the work into the sander.

Wear the proper protective clothing. Particles flying off of a sander will be traveling very fast-prepare for this. Wear safety glasses, face shield, a dust mask, earplugs, a leather apron, and heavy leather boots.

Remember that grinding often produces sparks. DO NOT allow anyone to stand in the path of the sparks. DO NOT grind near flammable materials.

Concentrate on the task at hand. STOP grinding if you are distracted.

Make sure side cover is closed and latched during operation.

BELT TRACKING

When first starting, the belt may not track centrally on the contact wheel.

To adjust the belt tracking:

- Turn the sander ON
- Making small adjustments, turn the belt tracking adjustment knob clockwise to move the belt to the left, or turn the knob counter clockwise to move the belt to the right
- Make sure the belt is not making contact with edge of the sander and that it is centered on the contact wheel.

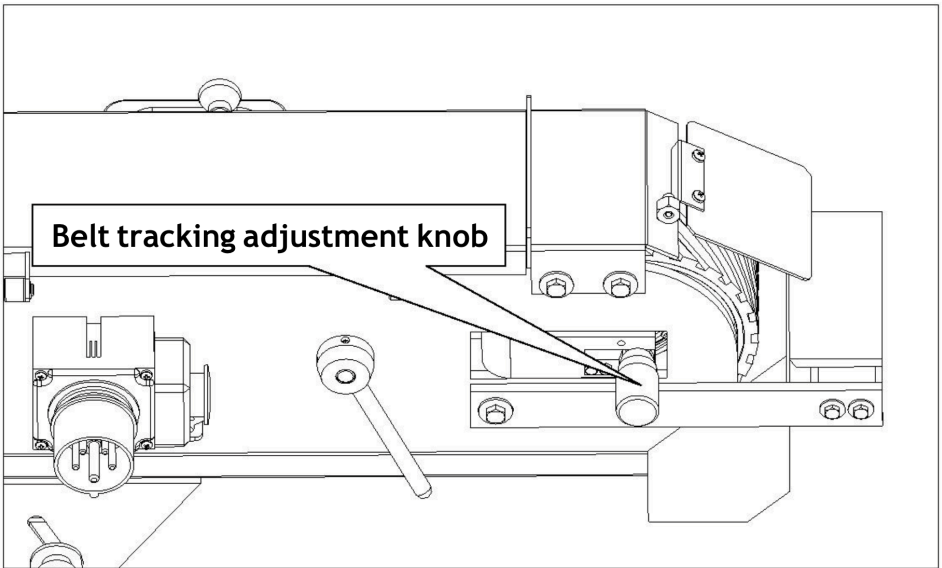

SCHEDULE

For optimum performance from your machine, follow this maintenance and cleaning schedule and refer to any specific instructions given in this section.

DAILY CHECK:

Loose mounting bolts.

Worn or damaged belt.

Clean and chips and debris between platen and sanding belt.

Empty spark trap.

Sweep surrounding dust and chips.

Sweep or vacuum dust and chips from the inside belt compartment and around motor.

CHANGING THE BELT

Changing the belt on the machine is quick and easy.

To change the belt:

1. Disconnect the sander from the power supply
2. Open the belt guard, remove the spark trap and open the side cover
3. Loosen the belt by pushing the belt tension lever all the way down and keep in place
4. Slip the belt off the wheels and replace with a new belt. Note the correct rotational direction of the belt.
5. Tighten the belt by pulling the belt lever all the way up
6. Spin the belt by hand to resume previous belt tracking. Adjust if necessary.
7. Close and latch the side cover, remount the spark trap and close the belt guard.

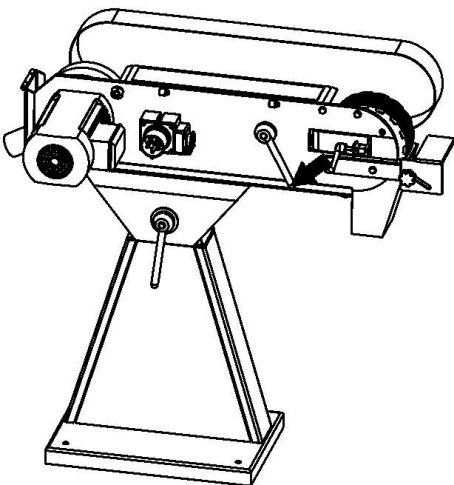

MAINTENANCE AND REPAIR

1. Metal belt sander should be placed in a surrounding where is dry and ventilated, and there is no eroding and harmful gas.
2. The outside cover of sand-band grinder and the grinding cap and dust in outlet should be frequently cleaned and keep these places tidy.
3. It would be better to replace the lubricating grease of the bearings in the motor of the sand-band grinder every 6-12 months.

TROUBLESHOOTING

Trouble	Possible cause	SOLUTION
Sander will not start	<ol style="list-style-type: none"> 1. Sander unplugged from wall or motor 2. Fuse blown or circuit breaker tripped 3. Cord damaged 	<ol style="list-style-type: none"> 1. Check all plug connections 2. Replace fuse or reset circuit breaker 3. Replace cord
Sanding belt does not come up to speed	<ol style="list-style-type: none"> 1. Extension cord too light or too long 2. Motor not wired for proper voltage 3. Low current 	<ol style="list-style-type: none"> 1. Replace with adequate size and length cord 2. Refer to motor junction cover for proper wiring 3. Contact a qualified electrician
Machine vibrates excessively	<ol style="list-style-type: none"> 1. Standing on uneven floor 2. Motor mounts are loose 3. Tension spring is worn or broken 	<ol style="list-style-type: none"> 1. Adjust stand so that it rests evenly on the floor 2. Tighten motor mount bolts 3. Replace spring
Abrasive belt keeps tearing	<ol style="list-style-type: none"> 1. Belt is running in the wrong direction 	<ol style="list-style-type: none"> 1. Arrow on the sanding belt and machine should be pointing in the same direction.
Sanded edge not square	<ol style="list-style-type: none"> 1. Table is not square to sanding platen 	<ol style="list-style-type: none"> 1. Use a square to adjust table to sanding platen
Sanding marks on wood	<ol style="list-style-type: none"> 1. Work held still 2. Wrong grit sanding belt 3. Feed pressure too great 4. Sanding against the grain 	<ol style="list-style-type: none"> 1. Keep work piece moving 2. Use coarser grit for stock removal and fine grit for finish sanding. 3. Never force work into sanding platen 4. Sand with the grain

ELECTRIC DIAGRAM

WIRE DIAGRAM (230V~,50HZ, 1-SPEED)

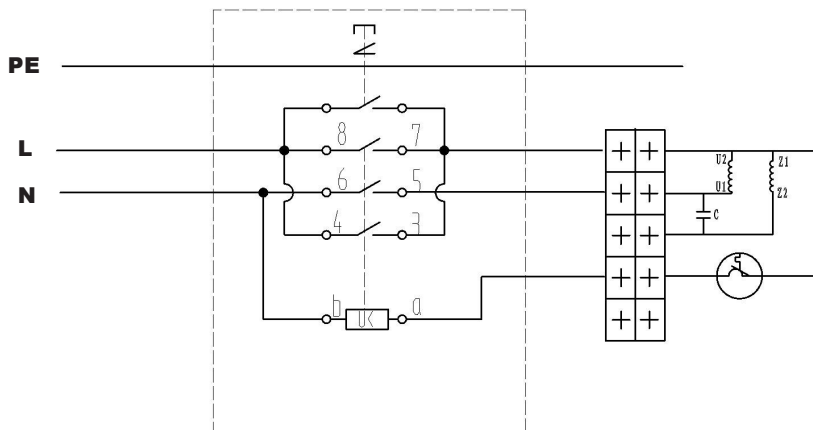

WIRE DIAGRAM (400V,3~,50HZ, 1-SPEED)

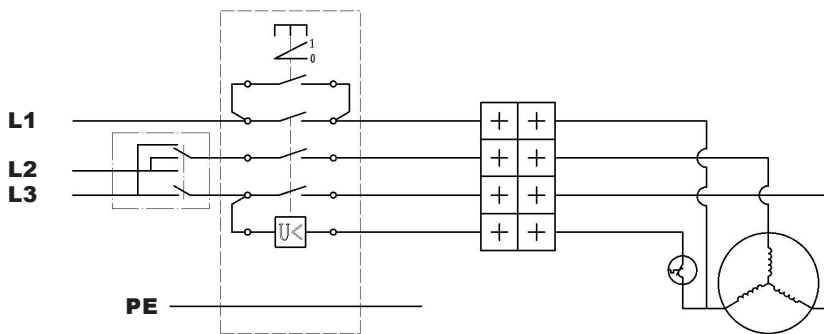

WIRE DIAGRAM (400V,3~,50HZ, 2-SPEED)

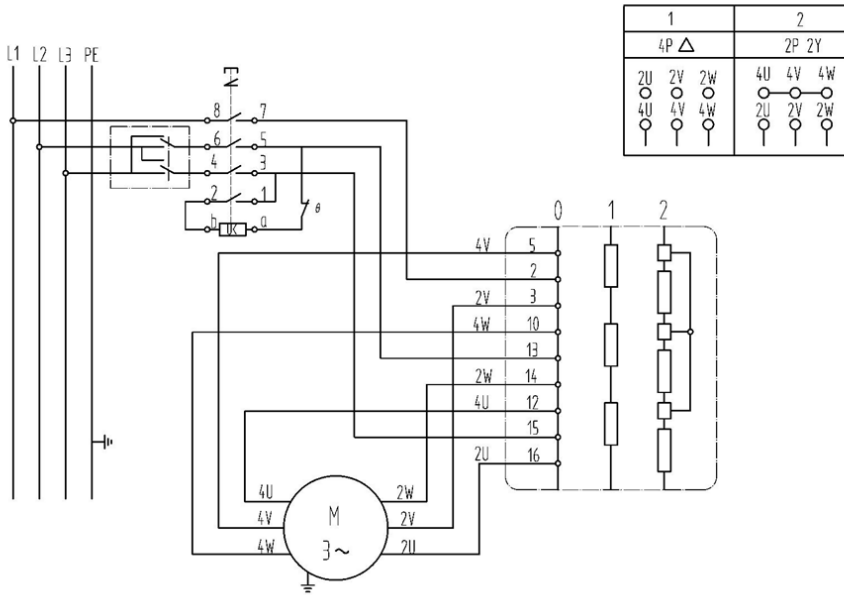

PARTS LIST & DIAGRAM FOR BELT SANDER

PART NO.	DESCRIPTION	PART NO.	DESCRIPTION
3	STAND BASE	59	BEVEL BLOCK
7	HEX NUT M16	60	HEX BOLT M5X16
8	SPRING WASHER 16	61	TABLE
9	WAHSER 16	62	HEX NUT M6
10	HEX BOLT M16X160	63	BIG WASHER 6
11	BIG WASHER 12	64	HEX BOLT M6X20
12	ANGLE ADJUSTMENT LEVER	65	HEX NUT M5
13	SPRING	66	WASHER 5
14	LOCKING HANDLE	67	EYE SHIELD
15	STEP SCREW	68	BRACKET
16	LOCKING KNOB	69	SCREW M5X10
17	BIG WASHER 8	70	SCREW M5X12
18	SPARK TRAP	71	WASHER 5
19	HEX BOLT M10X25	72	REAR SHIELD
20	SPRING WAHSER10	73	BIG WASHER 8
21	WASHER10	74	HEX BOLT M8X12
22	PIVOT BASE	75	TABLE SET PLATE
23	HEX BOLT M6X25	76	BIG WASHER 8
24	SPRING WASHER 6	77	HEX BOLT M8X20
25	BIG WASHER 6	78	ECCENTRIC WHEEL
26	LOCKING BUTTON	79	HANDLE REST
27	SANDER BELT	80	HANDLE
28	HEX BOLT M8X25	81	SET SCREW M6X12
28	SPRING WASHER 8	82	SWITCH BOX
30	BIG WASHER 8	83	SCREW M4X16
31	DRIVE WHEEL	84	PLUMBAGINOUS BOARD
32	HEX BOLT M8X25	85	E-RING RETAINING RING
33	SPRING WASHER 8	86	ACTIVE COVER
34	WASHER 8	87	SHOCK ABSORPTION PIECE
35	BODY	88	HEX BOLT M6X12
36	CIRCLIP FOR SHAFTS 24	89	HAND BALL

37	MOTOR	90	BELT TRACKING ADJUSTMENT KNOB
38	HEX BOLT M6X20	91	SET SCREW M6X6
39	SPRING PLATE	92	CIRCLIP FOR SHAFTS 25
40	HEX NUT M6	93	GUIDE PULLEY SPINDLE </td
41	SCREW M8X20	94	BEARING 6205
42	GRIPE	95	CIRCLIP FOR BORES 52
43	HEX NUT M8	96	CONTACT WHEEL
44	LOCKING KNOB	97	HEX BOLT M8X20
49	SPRING	98	SPRING WASHER 8
50	HEX BOLT M6X16	99	SPACE BUSH
51	SPRING PLATE	100	SUPPORT
52	LINK PLATE	101	DISTANCE STRIP
53	GUIDE PLATE	102	WASHER 6
54	SCREW M6X16	103	SCREW M6X10
55	GUIDE BELT REST	104	SPRING WASHER 6
56	PIN 8X40	105	HEX BOLT M6X20
57	SET SCREW M6X8	106	PROTECTIVE PLATE
58	SCREW M6X16	107	SCREW M6X12

