

GARRICK

Pressure Test Pump Model: TPRP50



Instruction Manual

Read this manual fully before use of the Test Pump and keep the manual in a safe place to ensure personal safety and as failure to use the pump correctly can affect warranty

The **GARRICK** manual Pressure Test Pump has been manufactured to pressure test installations of fluid carrying pipes for leaks prior to final commissioning. The Model TPRP50 is a precision tool which can test the installation integrity using either water or oil as a testing liquid and can test to a maximum pressure of 60 bar (860 psi)

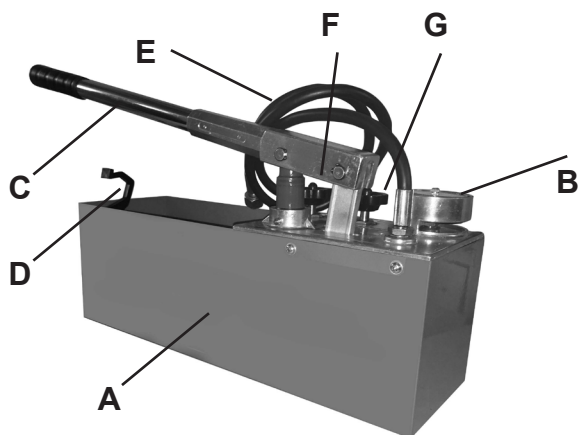

- A** Tank
- B** Pressure Guage
- C** Pump Handle
- D** Handle Lock
- E** Pressure Hose
- F** V2 - Purge Valve
- G** V1 - Shut-off Valve

Operating Instructions

- Connect the pressure hose to the installation being tested with Valve V1 open & Valve V2 closed.
- Open one or more purge points in the installation and pump liquid until all air has been removed from the installation. Close the purge points to seal the installation.
- Operate the pump until the desired test pressure has been reached.
- Close the Valve V1.
- After the pressure has been reached, wait for the pressure to stabilise (which depends on the size of the installation). If necessary pump further to reach desired pressure again.
- After stabilising, there should be no pressure drop on the guage if no leaks are present. When testing is complete, open both valves (V1+V2)

Note: Use only clean water or oil as a testing liquid. NEVER use Acids or other corrosive liquids as damage will occur to the pump & warranty will be void

Maintenance

The tank & pump system must be kept clean. The filter on the inlet from tank can become clogged with dirt or similar and should be cleaned with water to prevent entry of foreign material into the pumping system.

Lubricate the main piston periodically with water repellent grease. Be extremely careful not to mark or damage this piston.

AUSTRALIA



Garrick Herbert Pty Ltd

P.O. Box 3118

Kirrawee. NSW

(02) 9545 6633

www.garrickherbert.com.au

NEW ZEALAND



R.R. Bramley & Co. Ltd

P.O. Box 14-114, Panmure

Auckland. NZ

(09) 579 2936

www.bramley.co.nz