



Evaporative Air Cooler GPAC-120L



Please read manual before operating

Warranty

Any claim under this warranty must be made within 12 months of the date of purchase. Please note, that the 12 month warranty does not extend to products which have been altered, abused or not used in accordance with the operating manual.

To make a claim under warranty, take this up with the distributor you purchased through, have proof of purchase and they will call us at Garrick Herbert Pty Ltd.

Safety Notice

1. Do not put unnecessary things/objects into the air outlet as this will cause damage to the fan and could lead to injury
2. Always turn unit off and disconnect socket from wall before filling water tank
3. Do not stack items on the unit.
4. Do not let children or unqualified people operate the unit
5. Do not place burning apparatus near the unit as it may cause carbon monoxide poisoning.
6. Do not immerse product in liquid or allow to get wet.
7. Do not modify the unit in any way
8. Do not block any ventilation openings
9. Use appliance only for its intended use
10. Do not use appliance if it has been dropped or any part of appliance (including cord or plug) has been damaged. Take appliance to your nearest authorized service centre or qualified dealer for inspection or repair
11. Do not place the unit where there is explosive or flammable gas
12. If the machine will not be in use for a period of time, turn off the water supply and drain all water from the tank. Run the fan function only to dry the cooling pads.
13. This unit must have a reliable earth connection. If the earth wire is incorrectly connected or damaged it could cause electric shock or fire. It will need to be repaired by an authorized and qualified person.
14. Do not install the unit on other appliances, on uneven surfaces or where it could be subject to: heat sources (e.g. radiators or stoves), direct sunlight, excessive dust or mechanical vibrations. • Appliance should not be used outdoors, placed near a hot gas or electrical burner or placed in a heated oven. • Do not install near any heat sources such as radiators, heat registers, stoves, or other apparatus that produce heat.
15. Turn off and unplug the unit before moving. Move the unit slowly and carefully. Never let the water overflow. • Do not use the unit in very hot or humid places, such as kitchens, bathrooms or under direct sunlight
16. This unit is for INDOOR use only
17. Do not place this unit on uneven surface
18. Do not place this machine near curtains or anything else that could get caught
19. Electrical maintenance to be completed by a qualified person

Product Introduction

Evaporative air coolers use evaporation to cool the air. Evaporative coolers cool air by pulling fresh air from outside, filtering it through wet pads where the air is cooled by the evaporation of water. Evaporative cooling is basically the addition of water vapor into air. Evaporative cooling is a common form of cooling buildings since it is relatively inexpensive to run as it requires a smaller amount of energy than other methods of cooling. They can save up to 75% on cooling prices because the only mechanical component that uses electricity is the fan and water pump.

The performance of evaporative systems deteriorates as the humidity increases. Consequently, evaporative systems are not suitable for high humid regions. They are generally suitable for areas with dry summers, although their effectiveness will be reduced during the occasional periods of humid weather that these areas can experience. Evaporative air Coolers not only cool, but also humidify homes. This is why they will not do you much good if you live in a climate that is already very humid. Evaporative cooling is not suitable in areas that have both a high temperature and a high moisture content simultaneously. Evaporative coolers suit only dry climates where humidity is low. If you live in a very humid place, your evaporative cooler may not work as effectively as it does in dry areas.

If you live in a region where the summers are hot and dry, a portable evaporative cooler can be a cheap and effective way to keep you cool over those long sunny days. However, if you live in a humid area, they will not be the most effective option

Estimated Cooling at relative humidity

		Outdoor Humidity								
Outlet Temperature		10%	20%	30%	40%	50%	60%	70%	80%	90%
Outdoor Temperature	25°C	12.0	13.0	14.5	15.7	17.5	19.1	21.5	22.3	23.7
	27°C	13.5	14.5	16.5	17.4	20.0	21.2	23.0	24.6	27.0
	30°C	15.5	16.5	19.0	20.4	22.5	23.9	26.0	27.6	30.0
	32°C	17.0	18.0	21.0	22.6	25.0	26.6	29.0	30.4	32.0
	35°C	19.0	20.0	23.0	24.8	27.5	29.1	31.5	33.1	
	37°C	20.5	22.7	25.0	26.8	29.5	31.1	33.5		
	40°C	22.0	23.8	26.5	28.3	31.0	33.0			
	42°C	23.0	25.0	28.0	29.8	32.5				
	45°C	24.0	25.9	28.9	30.8					

How Evaporative Coolers work

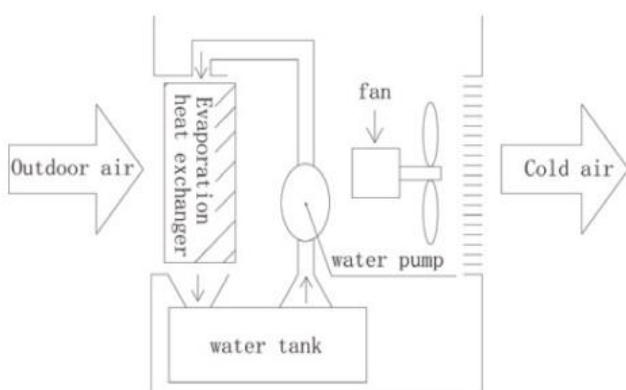







Operating Instruction

- 1 Open the box and make sure the unit is standing horizontal to the ground.
- 2 Make sure the voltage is in accordance with the local voltage before plugging in
- 3 Open the water tank and fill with clean water to the marked level
- 4 Connect the plug into the power source. Press the on/off button to turn on or off.
- 5 Once the machine is turned on press the cool button to turn on cooling mode. You will start to hear water moving as it is distributed to the pads. If you do not hear water check the water tank has water. If there is no water, the water pump will not turn on and a alarm will sound to remind you to turn the unit off and fill tank with water.
- 6 Choose the wind speed

Environment of use

- Ambient temperature 25-45 degree
- Relative humidity less than 90%
- Water supply 0-45 degree
- Deviation of voltage can not be more than 10% of rated voltage
- No corrosive gasses
- No flammable or explosive gas or dust

Warnings

-  This machine is to be used for indoor use.
-  Strictly prohibit the use in environments with flammable and explosive gases and to avoid long-term direct sunlight.
-  Do not place this machine on uneven or tilted surfaces as the machine may fall, causing damage to the machine body and internal parts.
-  Do not place the machine close to walls, curtains and other material as it will restrict the air intake and affect the air supply.
-  Do not tilt or use high impact force to the machine once water has been added.
-  Electrical maintenance must be completed by a qualified persons.
-  If the power cord is damaged, it must be replaced by the manufacturer, its service agent or similiary by a qualified persons in order to avoid a hazard.

Control Panel and Unit

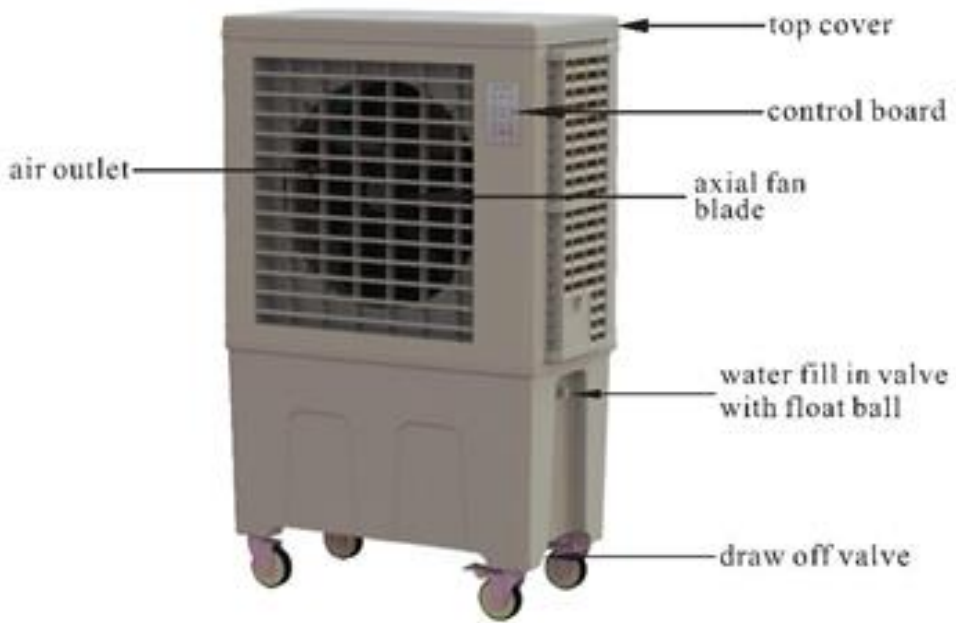
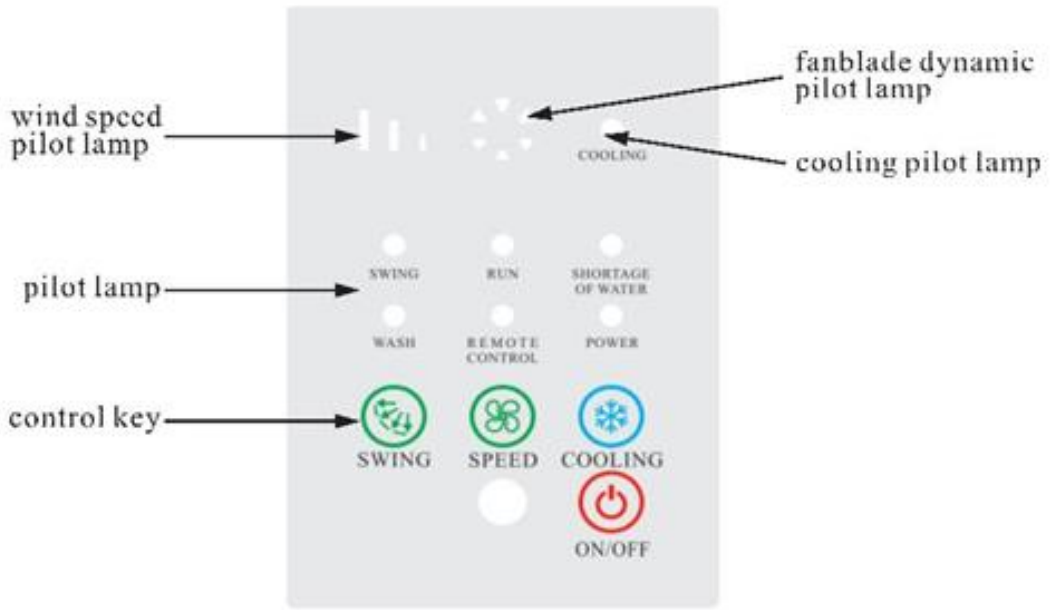

Product Care Instructions

Maintenance – Cleaning Filter Screen

Unplug the unit always during cleaning and refilling the water tank. Cleaning of the filter screen will be required monthly. Unscrew the 6 screws on the shutters. Do not use high water pressure when cleaning

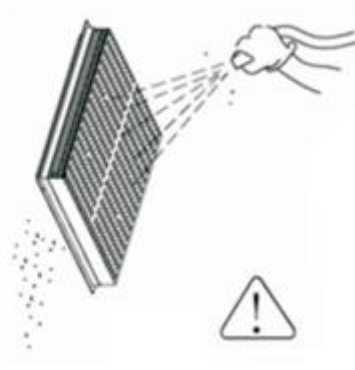
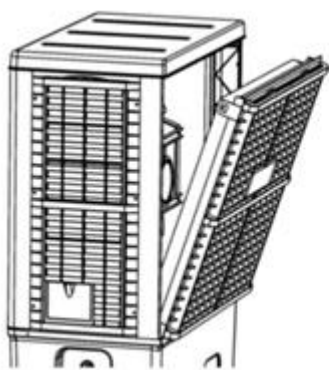

Maintenance – Cleaning Cooling Pads

Wash carefully with low water pressure / no detergents – just water.
Let dry completely before putting back in
Wash every 3-4 months

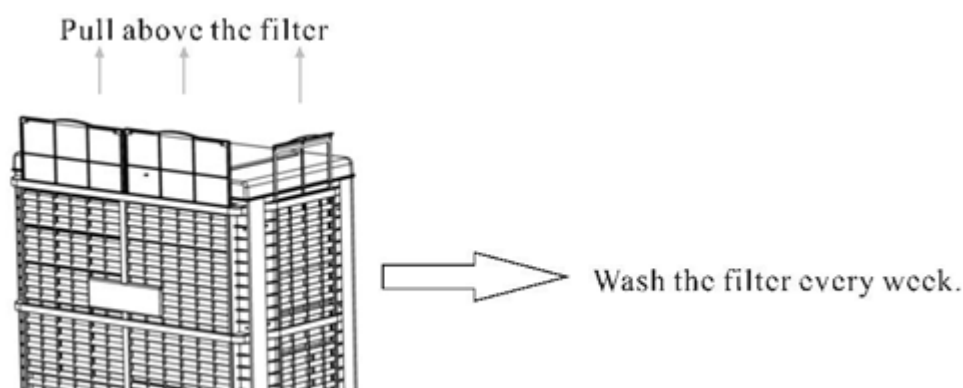

Maintenance – Water Tank

- 1 Turn unit off and Pull out the power supply plug, remove screws**
- 2 Wriggle the drainage valve at the bottom by hand to drain water
- 3 Use a soft cloth to wash chassis
- 4 Use a wet cloth to clean fouling on the water level sensor
- 5 Use brush to clean the fouling on the pump and filter

We recommend changing water at least once per week in the water tank

If the machine will not be in use for a period of time, turn off the water supply and drain all water from the tank. Run the fan function only to dry the cooling pads.

Troubleshooting

Fault	Possible reason	Solution
A. Unable to turn on/off	a. Is the unit connected to power? b. The control board has a fault	a. check the plug. b. change the control board - check for damage
B. Burnt Fuse	a. The submerged pump is broken	a. Change to a new submerged pump
C. Water leakage	a. Is the unit on a slant/not level? b. water tank leaks water c. Drain screw nut has come loose?	a. move the machine to a horizontal place b. repair the water tank c. Check the drain screw
D. Machine has become loud	a. the fan blade is dirty or broken b. have sundries on the air-intake or air outlet. c. motor is worn-out	a. clean or change the fan blade b. clean the barriers c. replace motor
E. No air supply or the wind speed is affected	a. wetted curtain / cooling pad or filter have been blocked up b. air blower does not work or works slowly	a. clean or change the wetted curtain /cooling pad and filter . b. check the motor if it is broken
F. Can not cool	a. does not have enough water in the water tank b. the water level control system has a fault c. submerged pump broken d. control board has a fault	a. add water into the water tank b. check the water level sensor c. change the submerged pump d. change the control board
G. There is white precipitation in the water tank or on the filter	a. The water from the watersupply is too hard	a. Add water softening solution

Technical Information & Wiring diagram

Product model	ZC-76Y3
Voltage/Hz	220V/50Hz
Power consumption	1.3A
Water consumption	6~11.5L/h
Air outlet size (mm)	605×635
Noise	64dB
Maximum airflow	6800m ³ /h
Power	300W
Water capacity	120L
Dimension (mm)	860×500×1380
Net weight	37kg
Blower style	axis-flow model

The maximum inlet water pressure is 5.9 Mpa.

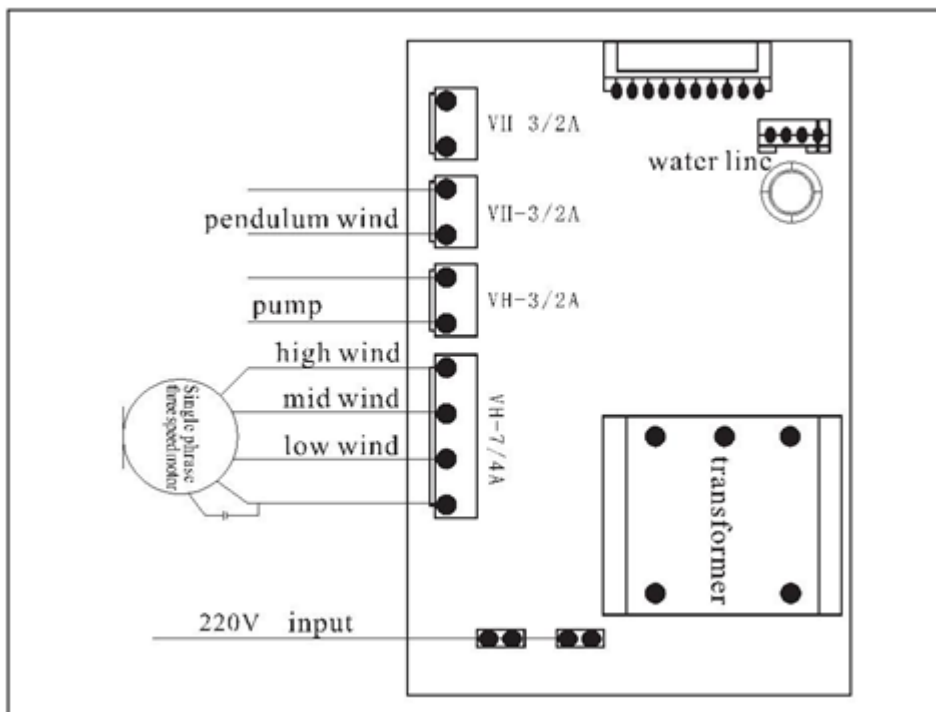



Evaporative Air Cooler GPAC-120L

Garrick Herbert Pty Ltd
460-462 The Boulevard
Kirrawee, NSW, 2232

PH: 02 95456633

sales@garrickherbert.com.au

www.garrickherbert.com.au

