

Bramley Model 64 Manual Tube Bender

BRAMLEY

Thank you for purchasing the Bramley Manually Operated Tube Bending Machine. This Machine has been designed to bend thin wall tube up to 90° in one operation. It is very versatile allowing a large variety of tube and steel to be bent. The Bender, as illustrated in Figure 1, includes the 1/2", 5/8", 3/4", 7/8" and 1" Formers for round tube. Also available are Formers that will allow other sizes of material to be bent. These are listed in Table A.

When ordering spare parts, please refer to the parts list - Table B. The parts are numbered on Figure 1 to allow easy identification of parts required.

Operation and Assembly

Upon receipt of your new Tube Bender, assemble the Handle to the Tube Bender Roller Support with the bolts supplied (see Figure 2 and 3). Figure 3 shows the Bender Body with Holes (A) drilled in the Base Foot and the Vice Clamp Block. These are for mounting the Bender permanently to a work bench, or the optional Support Stand. Alternatively, the Bender can be temporarily held in a vice by holding the Vice Clamp Block.

The Holes marked (B) in Figure 1 are used to position the Guide Block (Part No. 10). This Guide Block can be positioned anywhere over the eight holes to achieve the desired type of bend or radius. By moving the Guide

Block from one side to the other, the Bender may be operated in either a clockwise or counter clockwise direction.

The Holes marked (C) are used for securing the Former to the Body of the Machine. The Body offers two options for positioning the Former. The outside Holes are used for the small Formers and the inside Holes are used for the larger Former. The larger Formers can be located in both sets of Holes but unless a large bend angle is required, it is not recommended to locate the larger Former in the outer two Holes.

The Hole marked (D) is securing Hole for the Bar Stop Assembly. This should be bolted into

position when you receive your machine.

Figure 2 shows the Tube Roller Support Frame and handle assembled. Early models had four Holes for the location of the Guide Roller, more recent models have six. This allows better bending on the 1/2" and 5/8" Round Tube.

Figure 3 is a schematic diagram showing the side elevation of the assembled Bender. To change a Former it is a simple matter of removing the Pivot Pin. Once the Pivot Pin has been removed, the Support Assembly (Figure 2) can be removed leaving the Former bolted to the Body. Simply unbolt the Former and replace it with the size Former you require. Replacing the Support Assembly is a reversal of the removal procedure.

The Guide Roller can be positioned to achieve the type or radius of bend you require. However, it is preferable to position the guide roller in the closest possible hole to the tube being bent.

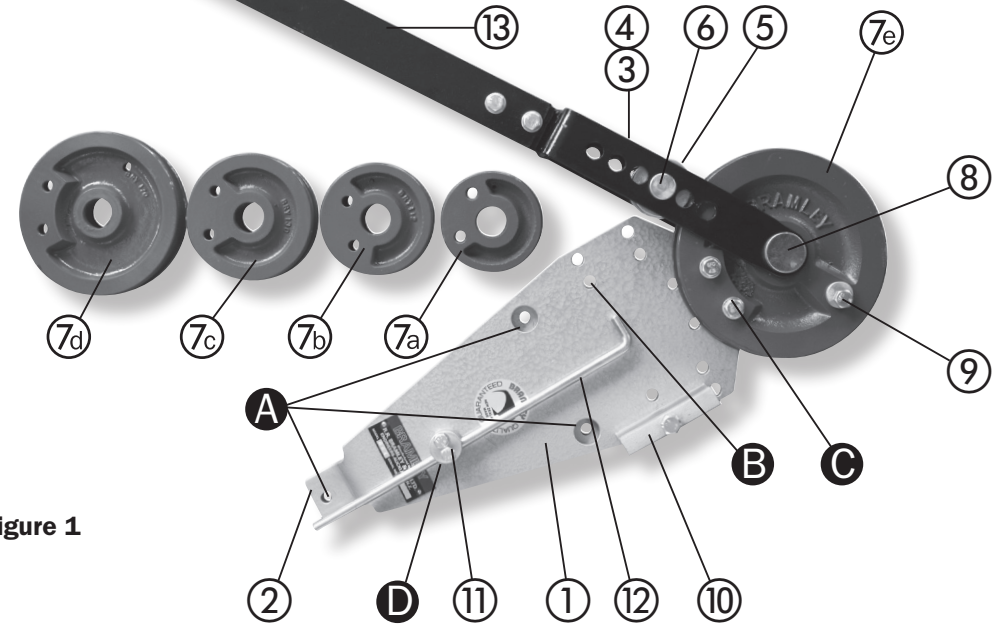

Figure 1

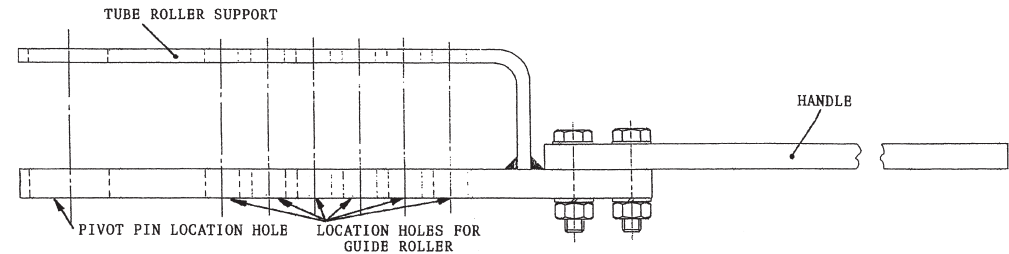

Figure 2

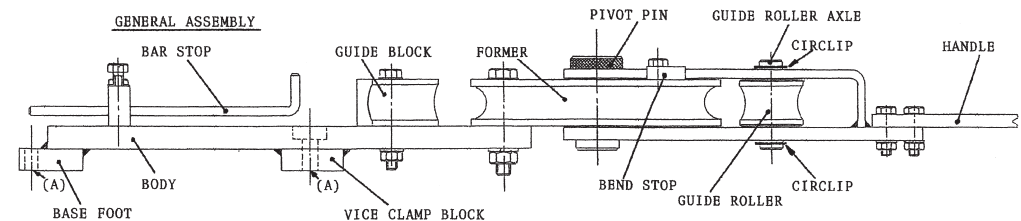

Figure 3

Round Formers		Square Formers	
Tube Size	Bending Dia.	Tube Size	Bending Dia.
1/2"	12.7mm	1/2"	108mm
5/8"	15.8mm	5/8"	140mm
3/4"	19.0mm	3/4"	170mm
7/8"	22.2mm	7/8"	196mm
1"	25.4mm	1"	190mm
1 1/8"	28.6mm		

Table A

Operating Instructions & Parts List

Bramley Model 64 Manual Tube Bender

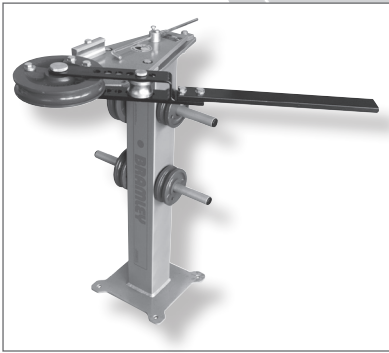

Bramley Manual Tube Bender mounted on optional Support Stand, which incorporates pegs for storage of Formers.

Part No.	Description	Material	Qty
1	Body	1/2" MS Profile Cut	1
2	Foot Base	MS: 50 x 16	1
2a	Vice Clamp Block	MS: 50 x 16	1
3	Low Support Roller	MS: 50 x 10	1
4	Upper Support Roller	MS: 50 x 5	1
5	Guide Tube Roller	BMS: 2 1/4" DIA	1
6	Pin Guide Roller	BMS: Ø 16mm or 5/8"	1
7a	1/2" Round Former	Casting BRY 100	1
7b	5/8" Round Former	Casting BRY 112	1
7c	3/4" Round Former	Casting BRY 130	1
7d	7/8" Round Former	Casting BRY 170	1
7e	1" Round Former	Casting BRY 200	1
8	Pivot Pin	BMS: Ø 1 1/8"	1
9	Washer CAM	BMS: Ø 25mm	1
10	Guide Block	BMS: 40 x 19	1
11	Bar Stop Slide	BMS: 32 x 15	1
12	Bar Stop	BMS: Ø 10 x 32 x 3mm plate	1
13	Handle	MS: 50 x 5	1
Accessories			
20	1 1/8" Round Former	Casting BRY 235	1
21	1/2" Square Former	Casting BRY 130	1
22	5/8" Square Former	Casting BRY 170	1
23	3/4" Square Former	Casting BRY 200	1
24	7/8" Square Former	Casting BRY 235	1
25	1" Square Former	Casting BRY 235	1
26	Flat Former	Casting BRY 200	1
27	Square / Flat Guide	BMS: Ø 2 1/4"	1

Table B: Spare Parts List

New Zealand

R.R. Bramley & Co Ltd

184 Marua Road, Mt Wellington (PO Box 14-114, Panmure)
Auckland, New Zealand.

Ph: +64 9 579 2036 Fax: +64 9 525 0735

Email: sales@bramley.co.nz

Web: www.bramley.co.nz

Australia

Garrick Herbert Pty Ltd

460-462 The Boulevard (PO Box 3118)
Kirrawee, NSW 2232, Australia

Ph: +61 2 9545 6633 Fax: +61 2 9545 4222

Email: sales@garrickherbert.com.au

Web: www.garrickherbert.com.au

USA & Canada

Garrick USA LLC

5455 West 6th Street (PO Box 874)
Winona, MN 55987, USA

Ph: +1 507 474 9660

Email: sales@garrickusa.com

BRAMLEY
Precision and Mechanical Engineers
Machine Tool Manufacturers



BRAMLEY

