

Pipe Threading Machine

**Asada**

# **BEAVER 50**

## **INSTRUCTION MANUAL**

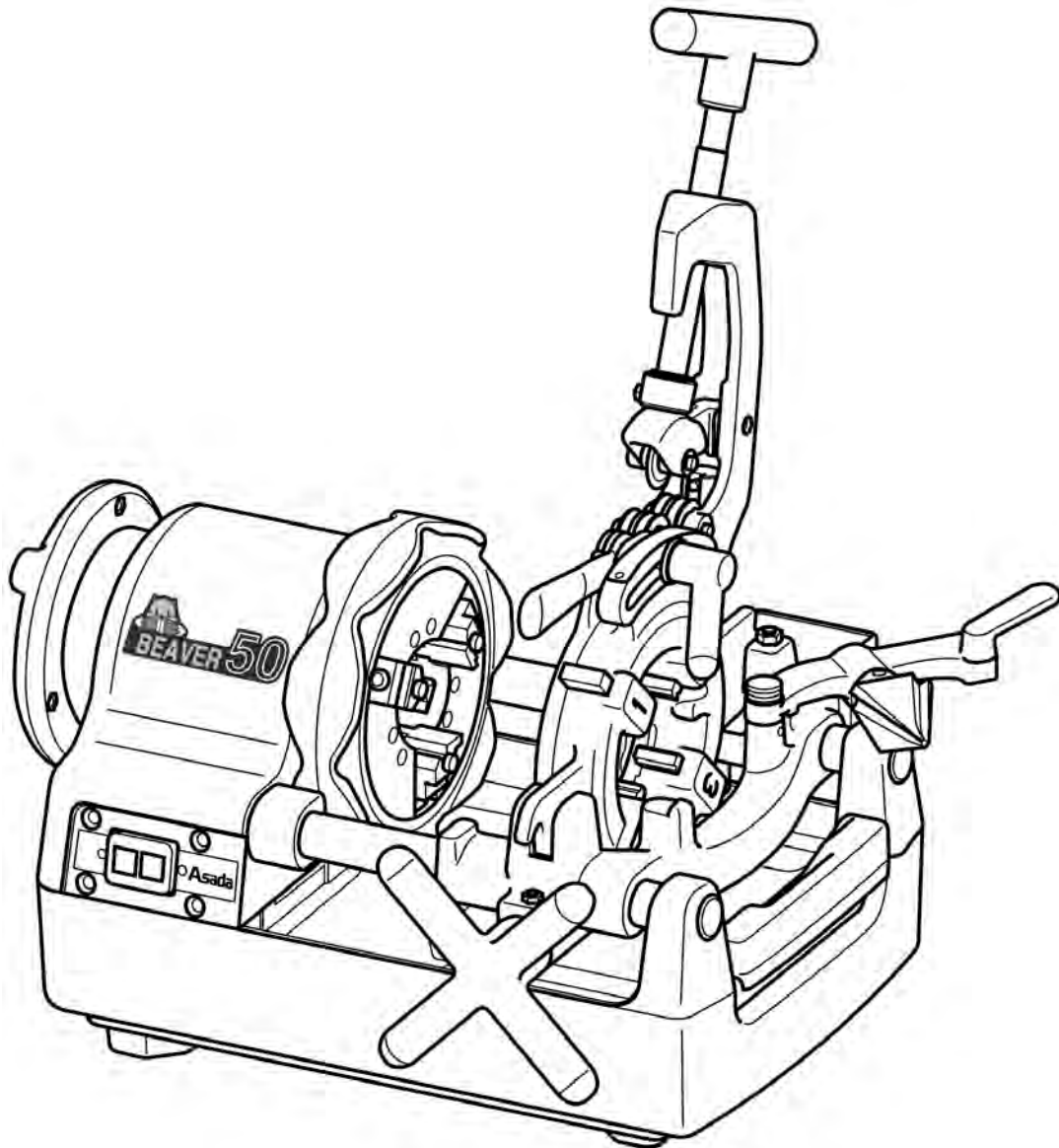

[Read through this manual carefully before using the machine]

## SAFETY PRECAUTIONS

Thank you for choosing our Beaver 50.

- \* This Instruction Manual must be retained by the user of this machine.
- \* Read this Instruction Manual carefully and completely before use and thoroughly understand the usage, capacity, cautions, and easy repairs for correct operation.
- \* Handle the machine properly to make full use of its functions for safe work.
- \* After reading the instructions, save this manual so that you can read it when necessary.
- \* Use the machine for the intended application only. It will do a better job and be safer at the rate for which it was designed.
- \* Upon receiving the machine, check the following.
  - Check that the machine is built conforming to the specifications stated in your order.
  - Check the overall machine for any damage or deformation caused in transit due to accidents or other reasons.
  - Check that all items and accessories delivered.

In case any discrepancy is found, immediately report the fact to the shop you purchased or our sale office. (The contents of this manual are subject to change without prior notice.)

## CLASSIFICATION OF CAUTIONS

Precautionary signs are classified into the following 3 levels.



**Indicates an imminently hazardous situation which, if not avoided, will result in death or serious injury.**



**Indicates a potentially hazardous situation which, if not avoided, could result in death or serious injury.**



**Indicates a potentially hazardous situation which, if not avoided, may result in minor or moderate injury. It may also be used to alert against unsafe practices.**

## SYMBOLS



Electric shock



Cutting Blade



Toxic Gas



Mask



Pinching



High Temperature



Splashing



Dragging



Explosion



Fire



Falling



Earth



Rotation parts



Other



Instruction manual

## CAUTIONS IN USE

### ⚠ DANGER

#### Electric Shock



- Always ground the machine to avoid electric shock or resultant death.
- Do not touch the plug with wet hands.
- Do not expose the machine to rain and water and do not use it in damp or wet locations. Humidity will deteriorate motor insulation or lead to electric shock.

#### Earth



- Immediately replace Power Plug, Power Cord or extension cord, if damaged.
- Do not hold the Power Cord and pull it to disconnect from the receptacle and do not put the machine on the cord and damage it.
- An extension cord used should be a three-core cable having an earth wire. Use a thick and durable cord for outdoor use.

#### Toxic Gas



- Toxic chlorine gas is generated. Do not burn the threading oil (Red). In case anyone should inhale the gas, move the person to a place of fresh air, and consult a doctor without a delay.
- Be sure to use the threading oil (White) for working water pipes.

#### Rotating parts



- The workpiece, Hammer Chuck and Scroll will rotate during working. Loose clothing can get easily tangled into moving parts.

### ⚠ WARNING

#### Fire



- Always use the machine at the voltage indicated on Machine Plate. Otherwise, the machine may become hot, emit smoke or catch fire.
- Do not force the machine in a manner that the motor stops due to an overload such as a worn Dies.
- Do not handle or use the threading oil near a fire.
- Immediately replace the Power Plug, Power Cord and extension cord, if damaged.
- If the machine has emitted smoke or took fire, do not disassemble it but have it inspected or repaired by a qualified person.

#### Explosion



- Never install an earth wire to the gas pipe. If attempted, explosion may take place.
- Do not use the machine in the presence of flammable liquids or gases such as gasoline and thinner. Otherwise, ignition or explosion may take place. Cutting Blade.

## WARNING

### Cutting blade



- Always wear gloves when replacing Dies, Reamer, Pipe Cutter and circular saw blade. Otherwise, you may cut your hands.
- The saw blade and other parts coast for a while after the switch is turned off. Never touch them while they are moving.
- Cut surfaces are very sharp and do not touch them with your hands.
- When it is required to touch the saw blade and moving parts for replacement, etc., switch off the machine and unplug it before starting that operation.

### Rotating parts



- Before plugging the machine in, always make sure that the switch is OFF. If the machine remains plugged in, it will start suddenly, leading to unexpected accident or injury.
- During operation, keep your hands and face away from the moving parts. You may be caught in the moving parts, causing injury.
- Do not use gloves for works such as cutting, reaming and threading.
- You may be caught in the moving parts, causing injury.
- Do not wear neckties, open-sleeved clothing, knitted gloves, loose clothing or jewelry (such as necklaces). Otherwise, you may get caught in moving parts.
- Wear caps or protective hair covering to contain long hair. Otherwise, you may get caught in moving parts.
- When not in use or when servicing, cleaning, checking or replacing parts, switch off and unplug the machine. If the machine remains plugged in, it will start suddenly, leading to accident or injury.

### Dragging



- Do not leave the machine unattended during rotating. Others may get caught in moving parts.
- It is mandatory to use Pipe Support for long and heavy work to avoid shaking and distortion of the work during turning and tilting of the machine by the weight of the workpiece. Otherwise, the workpiece and the machine become unstable.

### Splashing



- Wear safety glasses while operating the machine. Threading oil or chips enter your eyes and nose.
- Do not blow off chips using air. They may get into your eyes and loss of eyesight may result.

### Masks



- Use a face or dust mask if operation creates dust. Sawdust and dirt may enter your eyes and nose.

## WARNING

### High Temperature



- Immediately after threading, Dies, chips and threaded surface are hot. Do not touch them directly with hands.

### Other



- Fix the Carriage to avoid moving while carrying the machine, hold and lift the bottom of the machine. Do not carry the machine by the scroll or reamer to carry the machine.
- When lifting the machine, bend your knees to avoid a load on your waist.
- The machine stained with threading oil is slippery. Do not drop the machine on your feet while lifting it.
- Do not install the machine inclined or on an unstable place. The machine fall down, causing injury.
- Do not put the machine with the Die-Head side higher than the machine. Threading oil leaks from the inside of a pipe, staining the floor.
- Keep proper footing and balance at all times. You may tumble and get hurt.
- Do not operate the machine when you cannot concentrate on your work, e.g. when you are tired or while under the influence of alcohol, medication or drugs. Otherwise, accident or injury may occur.
- Before turning on the machine, make sure that hand tools used for inspection or adjustment are removed from the machine. Accident or injury may occur if you start the machine with hand tools on it.
- Use only the accessories and attachments given in this manual and our catalogs. A failure to do so will lead to accident or injury.
- Die-Head is wet and slippery with threading oil. Do not drop it on your feet while replacing.
- Drinking tap water mixed with threading oil may cause diarrhea or vomiting. Before laying pipings, always wash off threading oil from the threaded surfaces and the inside the piping.
- Always perform pressure test on threaded pipings. Otherwise, leakage of gas or water may occur.
- Immediately stop the machine if something is wrong with the machine or you have noticed unusual smell, vibration, sound, etc. during operation, and refer to "6. TROUBLE SHOOTING" in this manual and follow the corresponding instructions.
- Repair should only be carried out by our sales representative. Otherwise the machine may not show its performance or you may get injured. Ask the shop of your purchase or our sales office.
- Our products are in accordance with the relevant safety rules. Do not modify them.

# BEAVER 50

## CAUTION

### Electric Shock



- Do not put the machine or workpiece on the Power Cord. Damaged cord and current leakage will occur.

### Pinching



- Watch the position of your finger while lowering Die-Head to avoid pinching of fingers.

### Falling



- Do not leave the machine with a long workpiece set on it. You may tumble and get hurt.

### Instruction Manual



- Securely install accessories in accordance with this manual. Otherwise, accident or injury result.

### Other



- Before further use of the machine, a guard or other part that is damaged Should be carefully checked to determine that it will operate properly and perform its intended function.
- When the machine is carried with threading oil in it, the oil may splash and stain clothing due to vibration.
- If you have dropped or hit the machine accidentally, carefully check for damage, crack or deformation. If the machine is used with such defect, poor threading accuracy, accident and injury can result.
- Before leaving the machine for a long time, disconnect the Power Plug.
- Work wet with threading oil is slippery. Do not drop it on your feet.
- Always use the threading oil (White) for working water pipes. When the threading oil (White) is used, wash it off with water. When the threading oil (Red) is used, wipe it off with waste cloth. Avoid cutting your hands with threads and cut surfaces.
- The carriage contacts the body before the work is threaded and the Die-Head feeding stops. Start threading at a position 70 mm or more away from the Hammer Chuck.

## CAUTION

### Other



- **For proper threading, observe the following.**
  - Use the Die-Head and Dies which match the thread size.
  - Install the Die-Head on the Carnage properly.
  - Do not put Die-Head direct on the ground and handle it carefully.
  - Make sure that the threading oil pours on the Dies.
  - Avoid deformation and oblique cutting of pipes.
- **Keep your work bench and area tidy and well lit. Cluttered areas and benches invite injuries.**
- **Do not let visitors touch the machine and Power Cord or operate the machine.**
- **When not in use, machines should be stored in dry and high or locked-up place - out of reach of children.**
- **Threading Oil**
  - Threading oil contacting the skin may cause inflammation. Wear protective gloves when handling the threading oil. In case it contacts your hands, completely wash it off with water and soap.
  - Do not drink the threading oil because it causes diarrhea and vomiting. If swallowed accidentally, do not force to vomit and consult a doctor immediately.
  - Keep the threading oil out of reach of children.
  - Do not dilute the threading oil nor mix with other threading oil.
  - When the threading oil mixes with water and turns into milk-white or when it is extremely deteriorated causing poorly finished threads, early stage replacement with new oil is recommended.
  - Avoid direct sunlight and store in a dark place. After use, close up the container tightly to prevent dirt and water from entering.
- Do not inhale oil mist or vapor of the threading oil. It causes nausea. If inhaled accidentally, move to a place where fresh air prevails, cover the body to keep warm, lie quietly and consult a doctor.

### Explosion



- Dispose of waste oil and waste oil container as industrial waste. Do not heat the waste container, do not drill holes into it and do not cut it. Ignition or explosion may take place.

## CONTENTS

1.	OVERVIEW.....	8
2.	COMPONENTS OF THE MACHINE	
	1) Main Parts	
	1 – 1) Threading Machine.....	8
	1 – 2) Circular Saw.....	8
	1 – 3) Die-Head.....	9
	2) Specifications.....	9
	3) Standard Accessories Specification.....	10
	4) Optional Accessories.....	10
3.	INSTALLATION	
	1) Carrying the Machine.....	11
	2) Installation.....	12
4.	OPERATION	
	1) Preparing for Operation	
	1 – 1) Checking Threading Oil.....	13
	2) Setting the Workpiece.....	14
	3) Cutting	
	3 – 1) Pipe Cutter.....	15
	3 – 2) Circular Saw.....	16
	4) Reaming.....	17
	5) Changing Dies to Changed thread Size	
	5 – 1) Changing Dies to Changed thread Size.....	17
	5 – 2) Removing and installing Dies of Die-Head set in Carriage...	18
	5 – 3) Replacing Dies and Die-Head together.....	21
	6) Changing Thread Size .....	21
	7) Threading.....	22
	7 – 1) Adjustment of Thread Length.....	23
	7 – 2) Adjustment of Thread Depth.....	23
	8) Removing the Work piece.....	24
	9) Cleaning after Use.....	24
5.	MAINTENANCE & INSPECTION	
	1) Replacement of Parts	
	1 – 1) Replacement of Switch.....	25
	1 – 2) Replacement of Reamer Blade.....	26
	1 – 3) Replacement of Cutter Blade.....	26
	1 – 4) Replacement of Pump.....	27
	1 – 5) Replacement of Jaw Inserts.....	28
	1 – 6) Replacement of Carbon Brush.....	29
	2) Adjustment of Parts	
	2 – 1) Adjustment of Amount of Discharging Thread Oil.....	30
	3) Daily Inspection and Maintenance.....	31
6.	Before asking for Repairs.....	32
7.	ELECTRICAL WIRING DIAGRAM.....	32



## 1. OVERVIEW

- The pipe threading machine, model Beaver80, is intended to rotate a material such as a pipe and rod for cutting or threading. The machine consists of a motor which rotates a pipe and rod, etc. a Scroll and a Hammer Chuck to hold the work, a Cutter to cut the work, a Die-Head to thread the work, and a pump to lubricate the threading oil.

## 2. COMPONENTS OF THE MACHINE

### 1) Main Parts

#### 1-1) Threading Machine

- The diagram illustrates main parts and Die Head of this machine. Pipe is chucked by Hammer Chuck, cut by Cutter and threaded by Die Head.

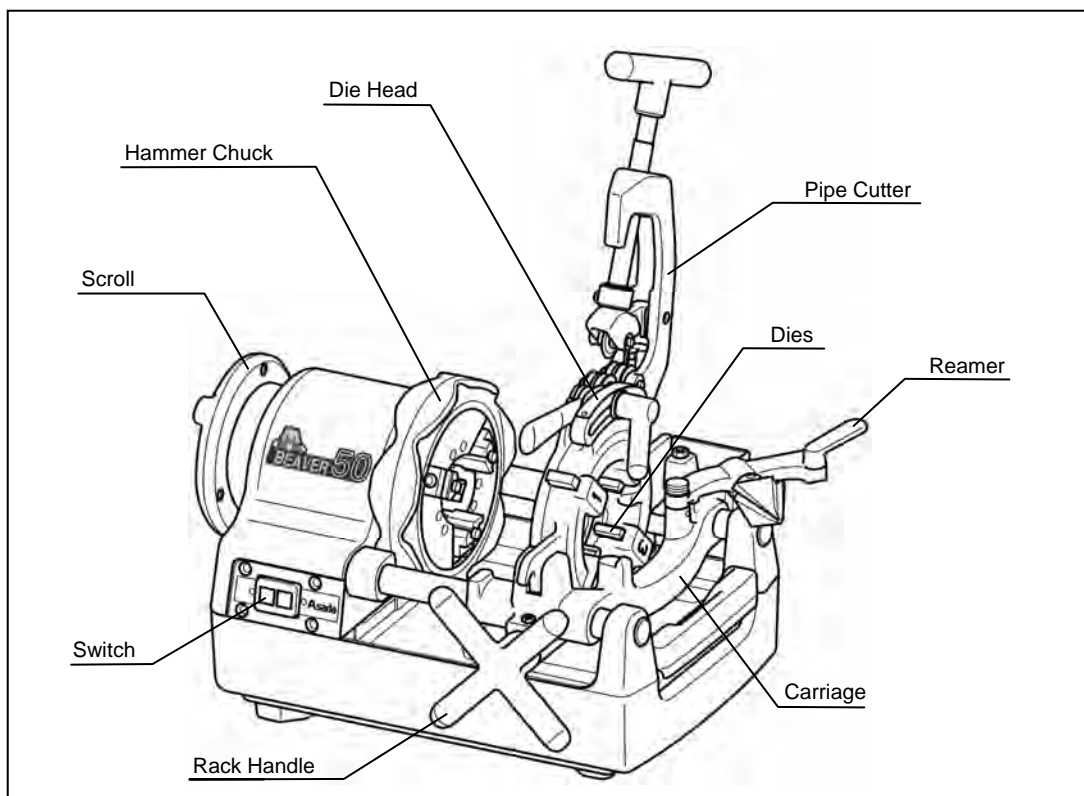

#### 1-2) Circular Saw

- The diagram shows the parts name necessary for description of this manual. For details, refer to the instruction manual of the Circular Saw.

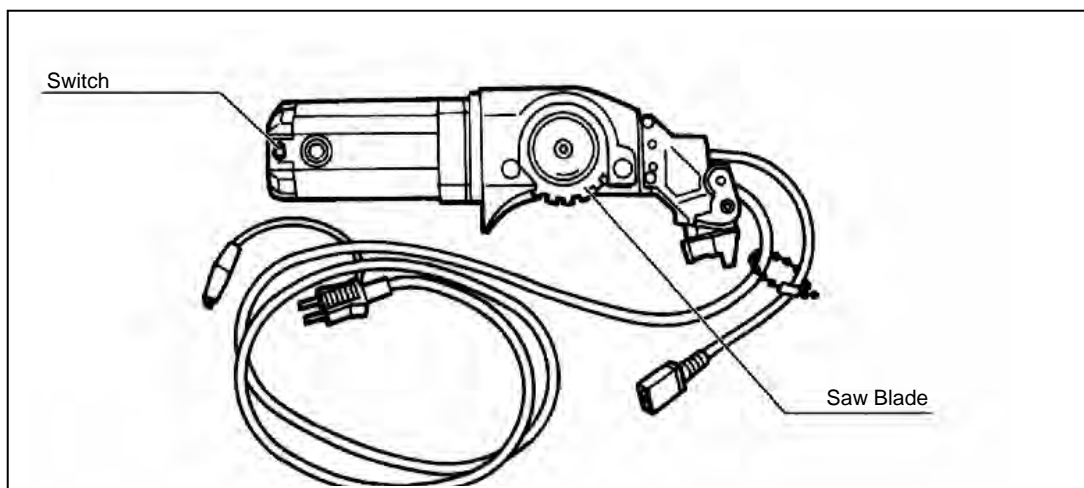

# BEAVER 50

## 1-3) Die-Head

- The diagram illustrates main parts of Die Head. Before changing the thread size, change Dies and position of Selector Block.

(1/2" – 2" Manual)

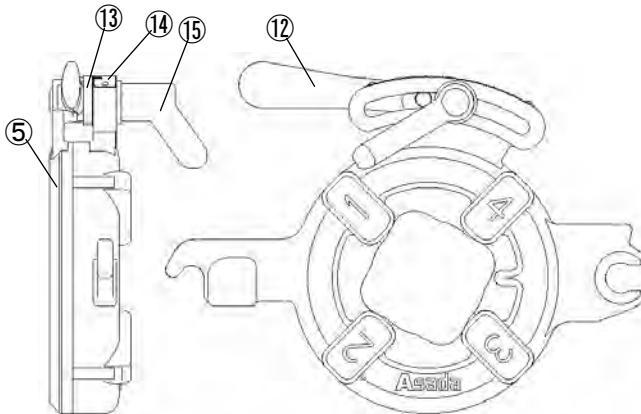

(1/2" – 2")

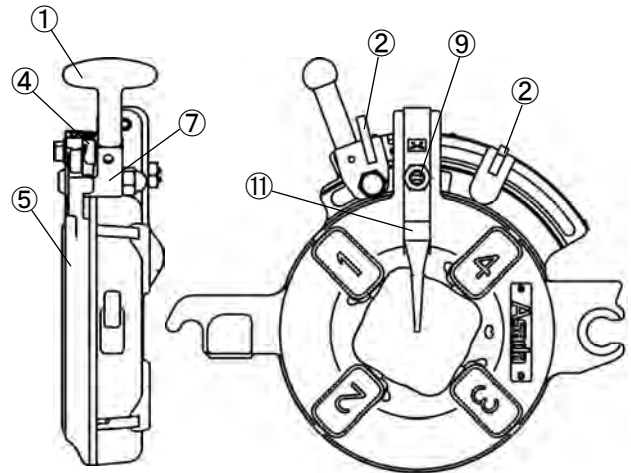

(1/2" – 2" AT)

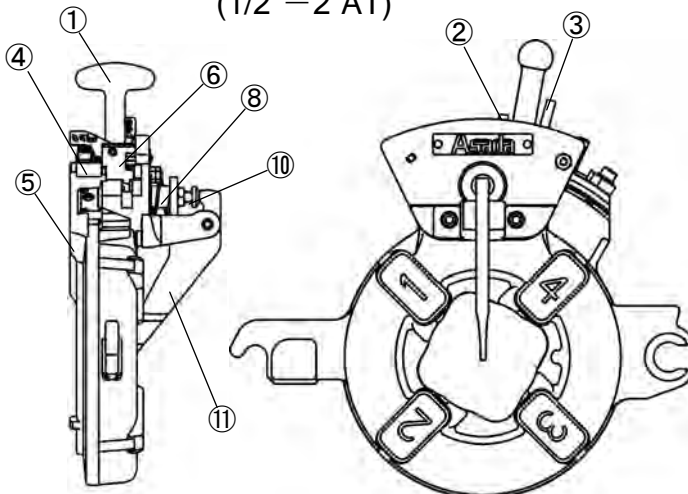

- |                         |                    |
|-------------------------|--------------------|
| ① T-Handle              | ⑨ Set Pin          |
| ② Selector Pin (silver) | ⑩ Adjust Screw     |
| ③ Selector Pin (black)  | ⑪ Locking Lever    |
| ④ Selector Block        | ⑫ Open Close Lever |
| ⑤ Cam Plate             | ⑬ Link             |
| ⑥ Profile Body          | ⑭ Scale Plate      |
| ⑦ Set Block             | ⑮ Die Nut          |
| ⑧ Profile Pin           |                    |

## 2) Specifications

<b>Cutting capability</b>	BSPT/NPT 1/4" ~ 2" (8A~50A) , Bolt 3/8" ~ 2"
<b>Speed</b>	40min <sup>-1</sup> (rpm) No load
<b>Motor</b>	Single phase Universal Motor, 750W
<b>Frequency</b>	50/60Hz
<b>Weight</b>	44k g
<b>Dimensions</b>	535 × 430 × 340mm (L) X (W) X (H)

\* Specifications are subject to change without prior notice.

\* Voltage made to order.

## 3) Standard Accessories Specification

Specification	Beaver50	
Die-Head	Manual Die Head 1/2" ~2"	Beaver Die Head 1/2" ~2"
Dies	1/2" ~3/4"	1" ~2"
Other	4L Threading oil, Tools, Machine Cover	

## 4) Optional Accessories



Bolt Die Head  
3/8"~2",  
10~36mm



Cutter Blade for Stainless Steel Pipe



Threading Oil 16L



Nipple Max PT1/2" ~2"



Taper Thread Gauge Set  
BSPT1/2" ~2"

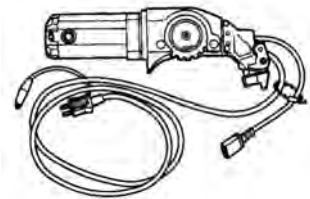

Circular Saw



Nipple Chuck  
BSPT1/2"~2",  
NPT1/2"~2"

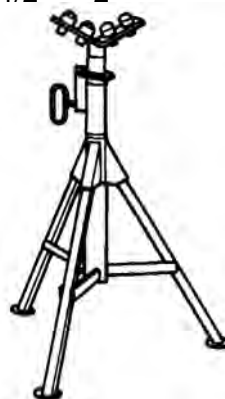

Pipe Jack with H ball

## 3. INSTALLATION

### 1) Carrying the Machine

#### WARNING



- Fix the Carriage to avoid moving while carrying the machine, hold and lift the bottom of the machine. Do not hold the scroll and reamer to carry the machine.
- When lifting it, bend your knees to avoid a load on your waist.
- The machine stained with threading oil is slippery. Do not drop the machine on your feet when lifting it.

#### CAUTION



- When the machine is carried with threading oil in it, the oil may splash and stain clothing due to vibration.

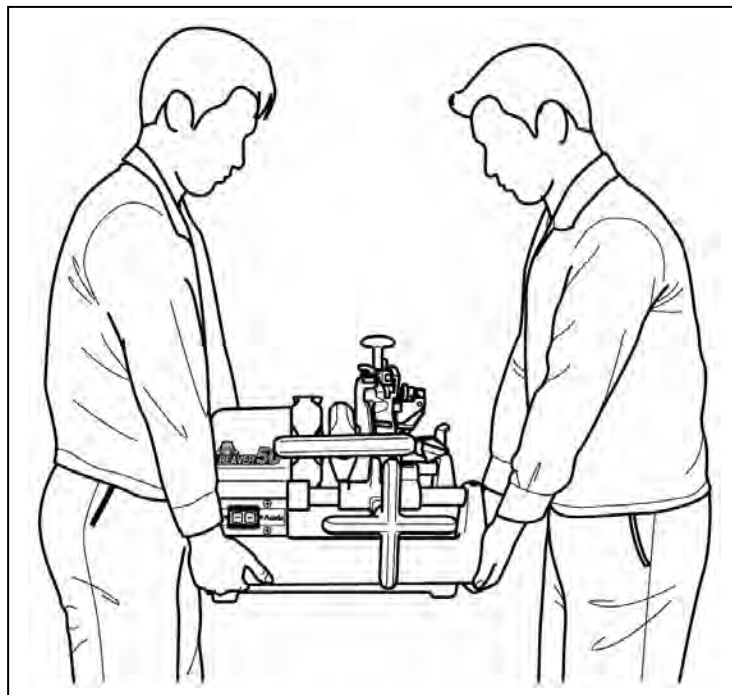

<1>

## 2) Installation

### ⚠ WARNING



- Always ground the machine to avoid electric shock and resultant death.



- An extension cord used should be a three-core cable having an earth wire. Use a thick and durable cable for outdoor application.
- Never install an earth on the gas pipe. Explosion may take place.

### ⚠ CAUTION



- Do not put the machine with the Die-Head side higher than other parts.
- Threading oil leaks from the inside of pipe, staining the floor.
- Do not use the machine in rain or outdoors. Die-Head or Dies will rust.

- (1) Put the machine in a place free from moisture.
- (2) Put the machine on a flat surface without play or on a flat work bench. In this condition, the Scroll side is higher than other parts. (fig.2)
- (3) Secure a sufficient space around the machine. A wide space is necessary particularly when working long and heavy pipe.
- (4) It is mandatory to use the Pipe Support for long and heavy pipe. Avoid excessive force applied to the machine which causes it to tilt.
- (5) Make sure that the power source is equipped with a ground fault circuit breaker to avoid electric shock.
- (6) Use an earth clip when a power receptacle without a base for grounding is used.
- (7) When an extension cord is used, use the one conforming to the applicable regulations.

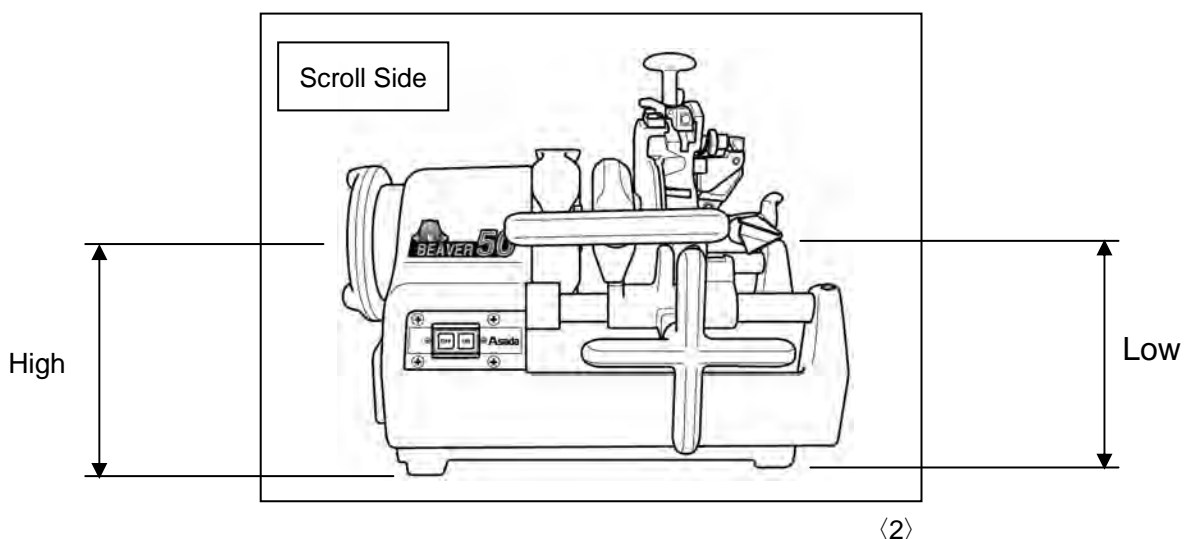

⟨2⟩

## 4. OPERATION

- The following gives a general description of threading work including the pipe cutting.
- (1) Prepare for operation. Check threading oil.
  - (2) Install the work on this machine.
  - (3) For cutting a work. Pipe Cutter operation and Circular Saw operation are different.
  - (4) In case of a pipe, ream the inner surface.
  - (5) Change the size of the thread as required. Please note that the operation method is different in Beaver Die-Head and Manual Die-Head.
  - (6) Thread the pipe.
  - (7) Remove the threaded pipe.

The following describes the contents of the above procedures.

### 1) Preparing for Operation

#### 1-1) Checking Threading Oil

- A new machine or a machine not used for a long period of time is coated with rust preventive oil. Wipe it off with a piece of clean cloth.

- (1) Turn Rack Handle clockwise to move the Carriage to the Chuck side.
- (2) Fill the provided threading oil from the right side of the machine up to the Strainer wire netting. (fig.3)

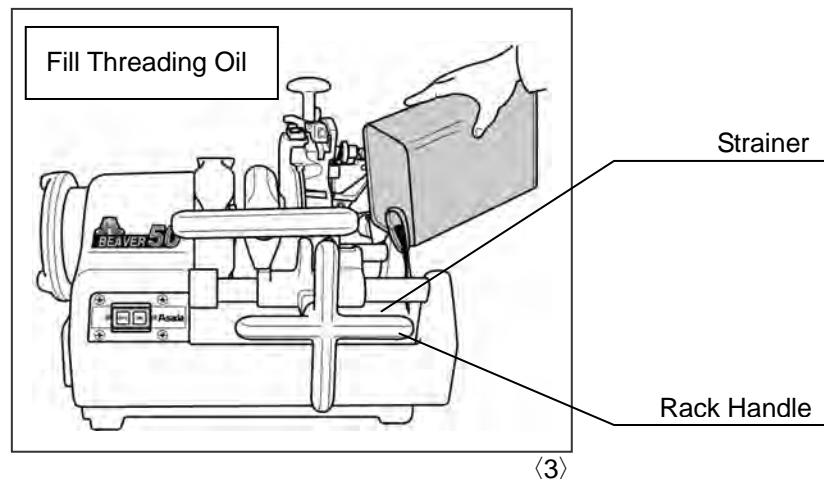

- (3) Make sure the machine is switched off and plug the Power Plug into receptacle. A two-core receptacle must always be grounded.
- (4) Switch on the machine and make sure the threading oil flows from the Die-Head. If proper amount of oil is not discharged, adjust with the Oil Adjust Screw., [Refer to Chapter 5. MAINTENANCE & INSPECTION 2-1) Adjustment of Threading Oil Discharge Amount].

## 2) Setting the Workpiece

### ⚠ CAUTION



- Do not thread the workpiece within 70 mm from the Hammer Chuck. The Carriage will touch the frame before threading is completed and the machine may be damaged.

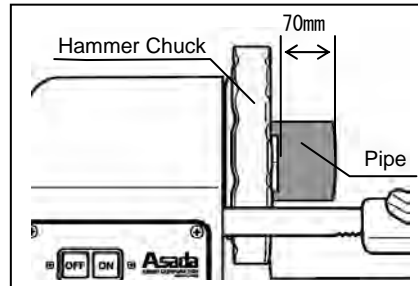

- (1) Swing the Cutter and the Die-Head upward to out-of-way position and set the Reamer at the back side.
- (2) Insert the workpiece from the Scroll side and tighten the Scroll. (fig.4,5)

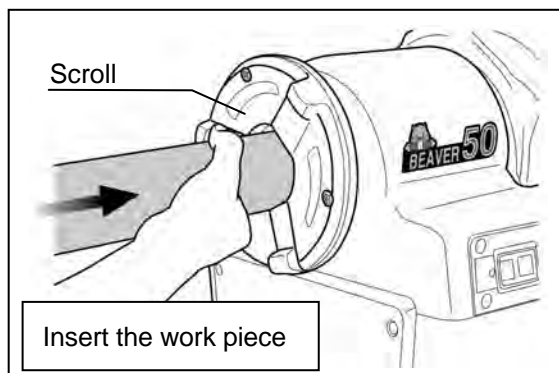

<4>

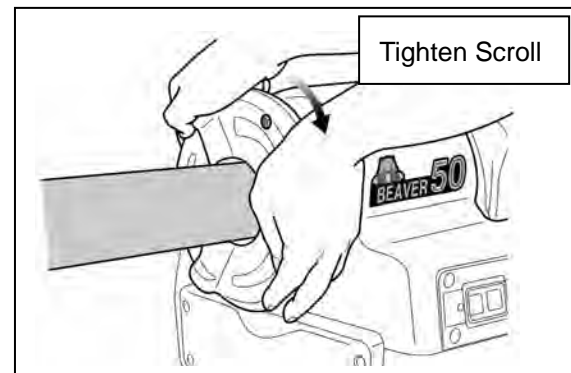

<5>

- (3) Hold the workpiece on the Hammer Chuck side in right hand and tighten the workpiece gradually with the Hammer Chuck. (fig.6)
- (4) Make sure three jaws contact the workpiece.
- (5) If three jaws do not properly contact the workpiece, the workpiece will shake and cutting and threading cannot be performed properly.
- (6) Chuck quickly and tighten the workpiece securely. (fig7)

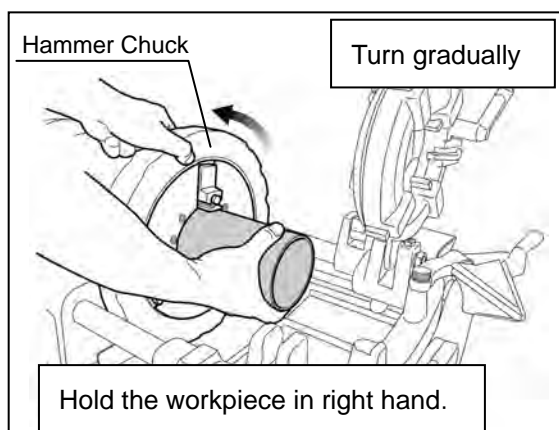

<6>

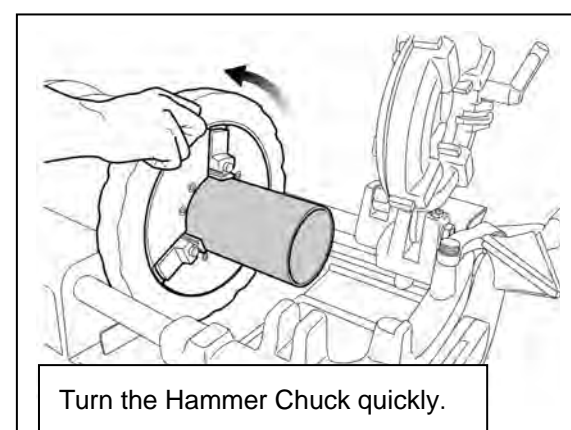

<7>

# BEAVER 50

## 3) Cutting

- Use the Pipe Cutter or Circular Saw for cutting the workpiece. Do not gather cut workpieces into the tank and take them out.

### 3-1) Pipe Cutter

#### ⚠ CAUTION



• Do not touch the cut surface with hands because it is hot and sharp.



• If the Cutter Handle is turned forcibly, the cut section of piping forms an oval shape, preventing proper threading. Turn the Cutter Handle a half turn per one turn of the pipe.

- (1) Swing the Pipe Cutter upward to out-of-way position, turn the Rack Handle to move the Pipe Cutter to the position for cutting the workpiece. (fig8)

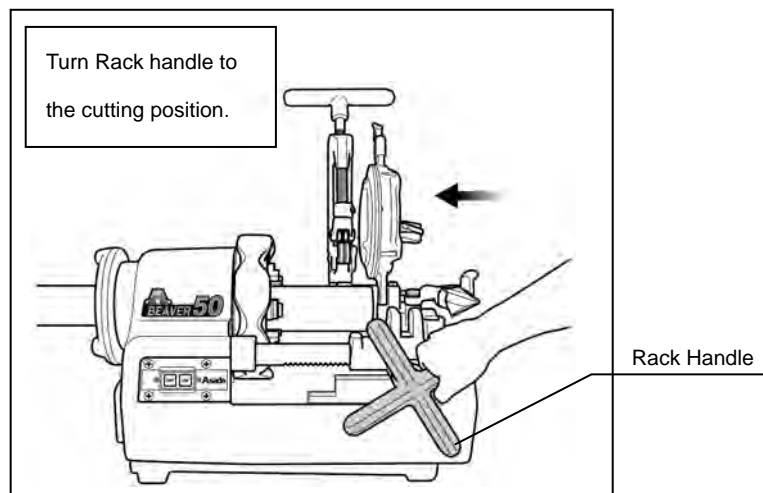

⟨8⟩

- (2) Move the Pipe Cutter down on to the work piece, then turn the Switch ON.
- (3) Turn the handle clockwise with a force and start cutting the workpiece. (fig.9)

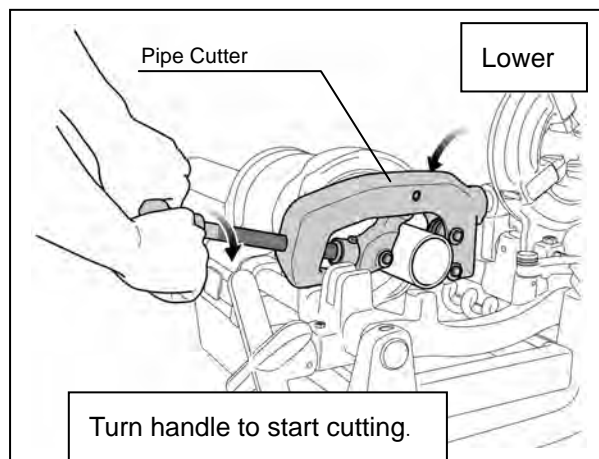

⟨9⟩

- (4) Swing the Pipe Cutter upward to out-of-way position and return.
- (5) Do not gather cut pipes in the tank. Remove them from the tank.



## 3-2) Circular Saw

- For installation and handling, refer to the Instruction Manual of the Circular Saw.

### ⚠ CAUTION



- Always use the machine at the voltage indicated on Machine Plate. Otherwise, the machine may become hot, emit smoke or catch fire.



- The saw blade and other parts coast for a while after the switch is turned off. Never touch them while they are moving.



- Do not leave the circular saw when the blade is turning.

- Blade and chips of the circular saw is hot immediately after cutting. Do not touch them with bare hands.



- Always wear gloves for installing the circular saw or replacing the blade.

- Switch the machine off, disconnect the Power Plug, switch off the circular saw and install it on the body.

- Accident or injury may occur if the machine is operated with its acrylic cover open, exposing the blade.

- Do not push the workpiece against the circular saw. Blade will be

- (1) Swing the circular saw upward to out-of-way position, turn the Rack Handle to move the Saw Blade to the position for cutting the workpiece. (fig.10)

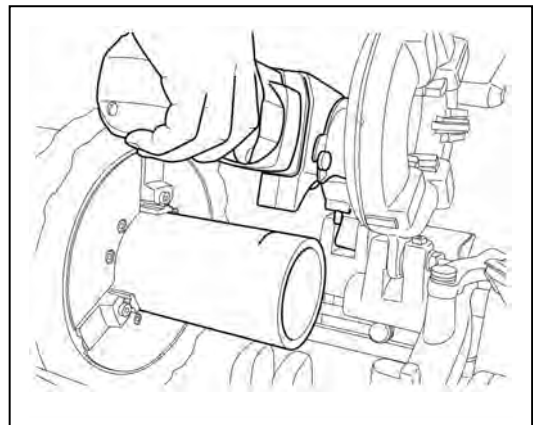

<10>

- (2) Switch on this machine and the Circular Saw. (fig11)

- (3) Lower the Circular Saw and put it on the workpiece slowly. (fig12)

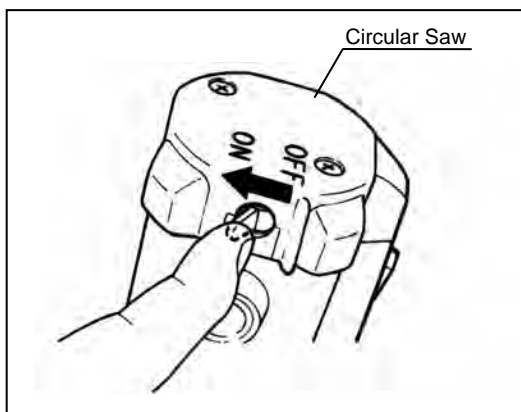

<11>

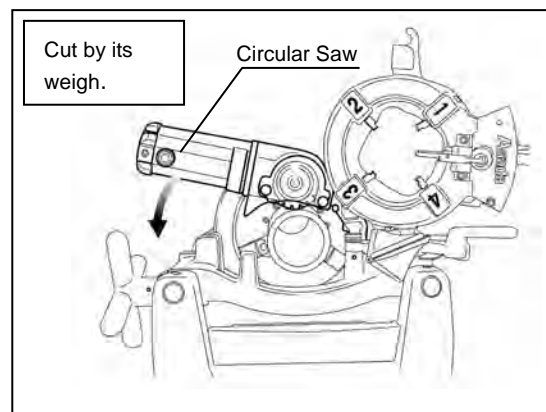

<12>

- (4) After the workpiece is cut, switch off the circular saw and slowly swing it to out-of-way position.

# BEAVER 50

## 4) Reaming

### ⚠ CAUTION



• Blade tip of the Reamer is very sharp. Do not touch it with bare hand.

- (1) Ream the inner surface of the pipe cut with the Cutter.
- (2) Pull the Reamer toward you and set the pipe. (fig13)
- (3) Turn the Rack Handle clockwise to move the Reamer Blade close to the end face of the turning pipe.  
(fig13)
- (4) Turn the Rack Handle further, lightly press the Reamer Blade against the inside the pipe for reaming.  
(fig13)

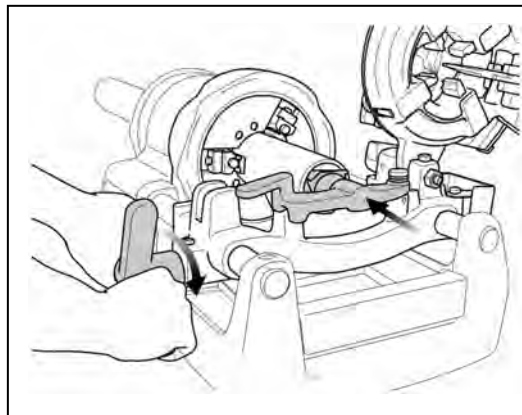

〈13〉

## 5) Changed thread Size

### 5-1) Changing Dies to Changed thread Size

- For thread size [1/2"] and [3/4"], use Dies [1/2" – 3/4"].  
For pipe size [1"], [1-1/4"] [1-1/2"] and [2"], use Dies [1" – 2"].
- For thread size changed from [1/2"], [3/4"] to [1"], [1-1/4"], [1-1/2"], [2"] or vice versa. Dies replacement is also necessary as follows.  
[Replace Dies (4 locations) of Die-Head set in the Carriage.]

## 5-2) Removing and installing Dies of Die-Head set in Carriage

■ For Beaver Die-Head 1/2"-2"AT

[Removal]

**CAUTION**



•Wear gloves to avoid cutting hands by the Dies.

- (1) Pull Locking Lever toward A to open Dies.
- (2) Set Selector(silver) Pin into the Dies Selector Block.
- (3) When the Die-Head is lowered, pull out Dies Nos. 1 and 4 from above.
- (4) Lift and remove the Die-Head and pull Dies Nos. 2 and 3 downward.

[Installation]

**CAUTION**



•Proper threading cannot be achieved unless the number on the Die-Head slot matches that of the Dies.

- (1) Pull Locking Lever toward A to open Dies.
- (2) Set Selector Pin(silver) into the Dies Selector Block.
- (3) Insert the Dies with the same number as that of each Die-Head until click sound is heard.
- (4) Make sure the numbers of Die-Head and Dies show on the same side.

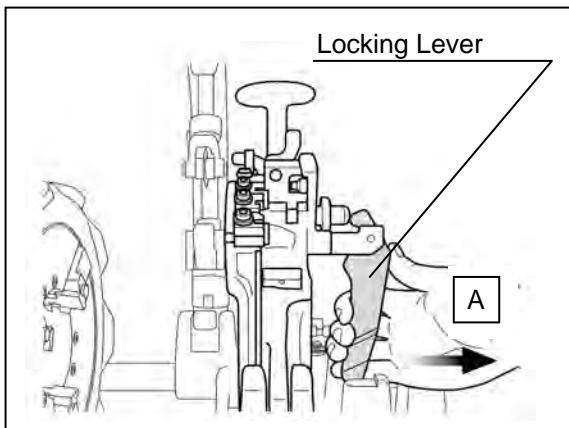

<14>

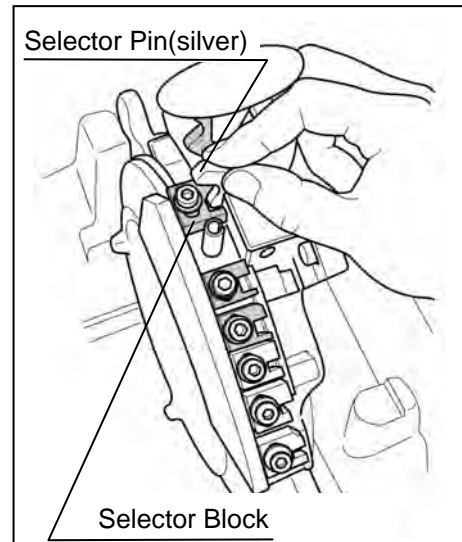

<15>

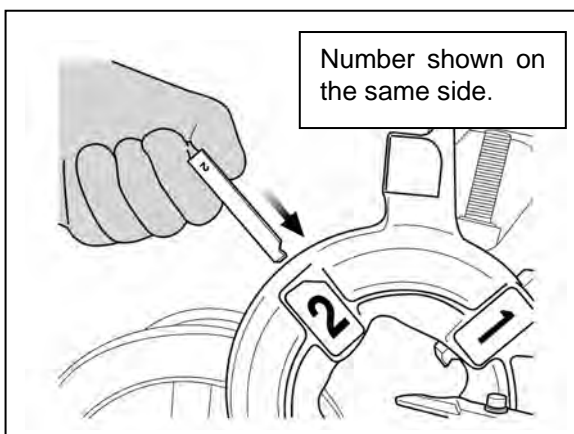

<16>

# BEAVER 50

## ■ For Beaver Die-Head 1/2"-2"

### [Removal]

**CAUTION**



•Wear gloves to avoid cutting hands by the Dies.

- (1) Remove the Location Plate. Pull locking lever toward “A” to open dies. Slide cam plate fully toward ”B” .(fig.17)
- (2) When the Die-Head is lowered, pull out Dies Nos. 1 and 4 from above.
- (3) Lift and remove the Die-Head and pull Dies Nos. 2 and 3 downward.

### [Installation]



•Proper threading cannot be achieved unless the number on the Die-Head slot matches that of the Dies.

- (1) Remove the Location Plate. Pull locking lever toward “A” to open dies. Slide cam plate fully toward ”B” . (fig.17)
- (2) Insert Dies with the same number as that of Die-Head until click sound is heard. Make sure the numbers of Die-Head and Dies show on same side.(fig.18)
- (3) Side cam plate toward “C” until a click sound is heard form locking lever. (fig.19)

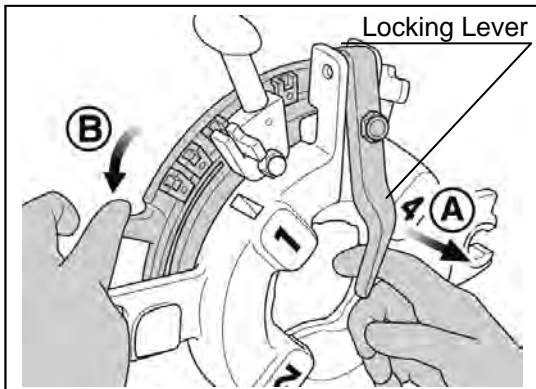

〈17〉

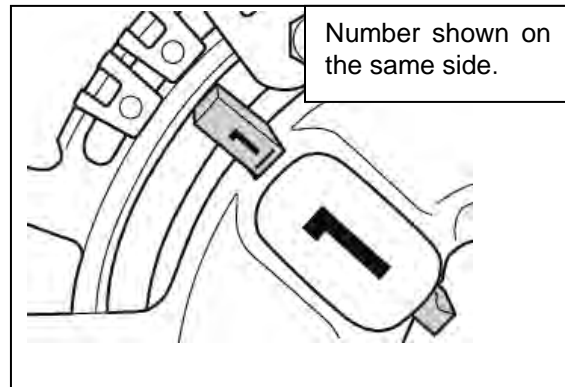

〈18〉

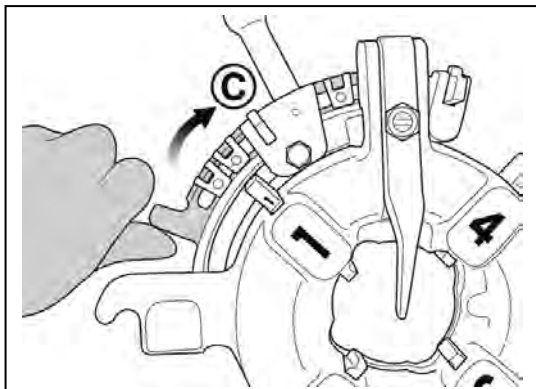

〈19〉

## ■ For manual Die-Head

### [Removal]

**CAUTION**



·Wear gloves to avoid cutting hands by the Dies.

- (1) Loosen The Die-Nut, lower the link fully, tighten the Die-Nut and throw the Open-Close Lever up to remove the Dies.(fig.20)
- (2) When the Die-Head is lowered, pull out Dies Nos. 1 and 4 from above.
- (3) Lift and remove the Die-Head and pull Dies Nos. 2 and 3 downward.

### [Installation]

**CAUTION**



·Proper threading cannot be achieved unless the number on the Die-Head slot matches that of the Dies.

- (1) Loosen The Die-Nut, lower the link fully, tighten the Die-Nut and throw the Open-Close Lever up to remove the Dies.(fig.20)
- (2) Insert the Dies with the same number as that of each Die-Head until click sound is heard.
- (3) Make sure the numbers of Die-Head and Dies show on the same side.

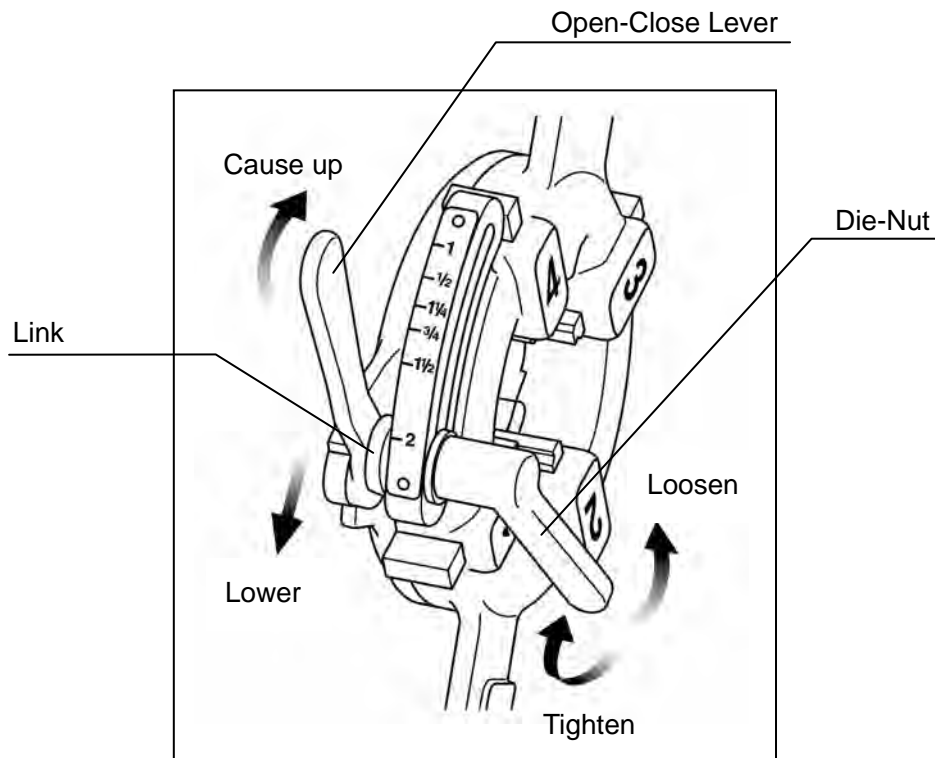

<20>

# BEAVER 50

## 5-3) Replacing Dies and Die-Head together

### [Removing and Installing Die-Head from Carriage]

- (1) Lift the Die-Head halfway.
- (2) Position Die-Head on the diagonal and remove.
- (3) Only when the Die-Head is adjusted parallel with the flat surface of the Die Head Pin, can it be removed or installed from the machine.

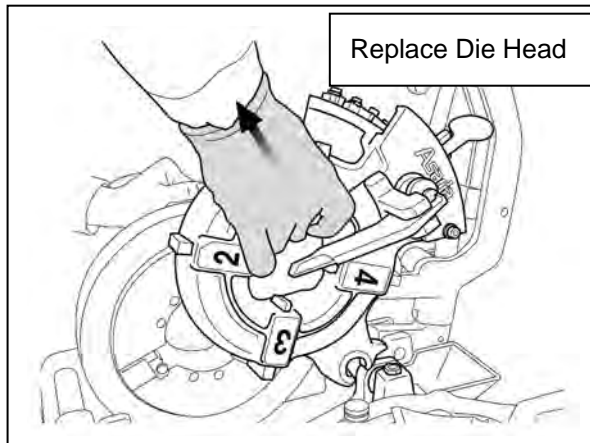

⟨21⟩

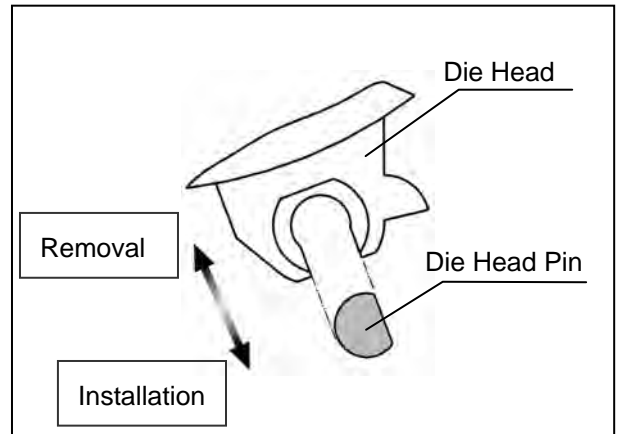

⟨22⟩

## 6) Changing Thread Size

### ■ For Beaver Die-Head 1/2"-2" AT

- (1) Make sure that the Die-Head is set on the Carriage and that the Dies corresponds to the thread size.
- (2) Set Selector Pin into Selector Block of the required threading size. (fig.23)
- (3) Size indicated on each Selector Block.

Use silver Selector Pin and block for 1/2" to 1" and black ones for 1 1/4" to 2".

### ■ For Beaver Die-Head 1/2"-2"

- (1) Ensure that the Die-Head is on the tool carriage and that the Dies correspond to the thread size.
- (2) The size is shown on the respective selector block. (fig.24)

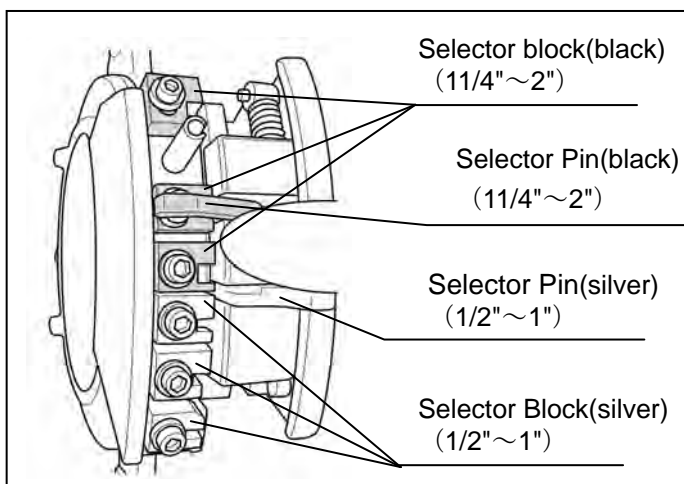

⟨23⟩

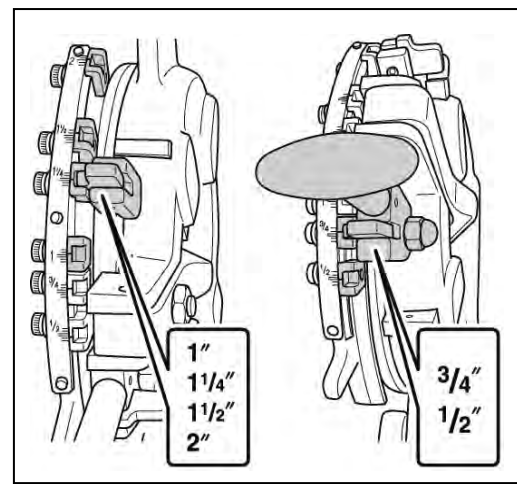

⟨24⟩

## ■ For Manual Die-Head

- (1) When the Die-Nut has been loosened, the Link goes up and down. Match the eye-work of the Link with the predetermined scale graduation on the Scale-Plate. (fig.25)

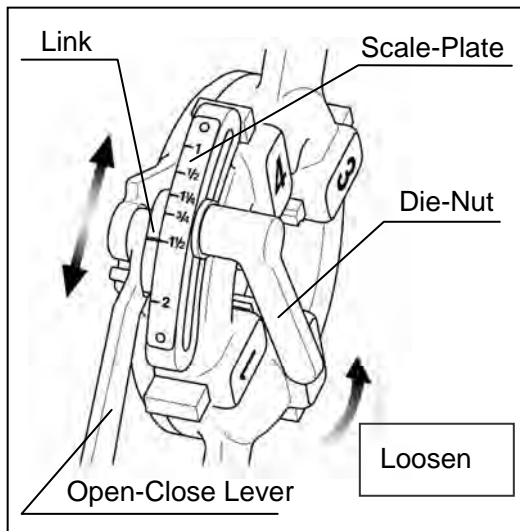

<25>

## 7) Threading

### ▲ CAUTION



- Watch the position of your hands while lowering Die-Head to avoid pinching.

## ■ For Beaver Die-Head

- (1) Lower the Die-Head and set T-Handle with it fully pressed toward B. (fig.26)
- (2) Turn the switch ON, turn the Rack Handle clockwise with pressing Dies to the work piece.
- (3) Take hands off from the Rack Handle after two or three threads were cut. (fig.27)
- (4) Dies are opened automatically when threading done. Switch off when the threading is completed.

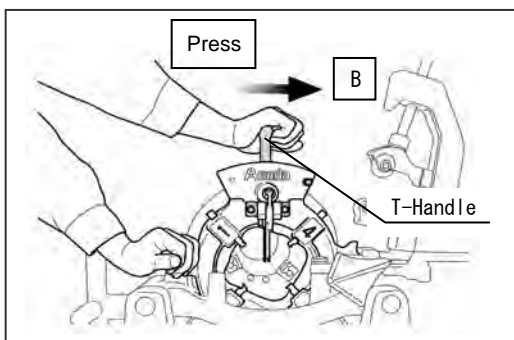

<26>

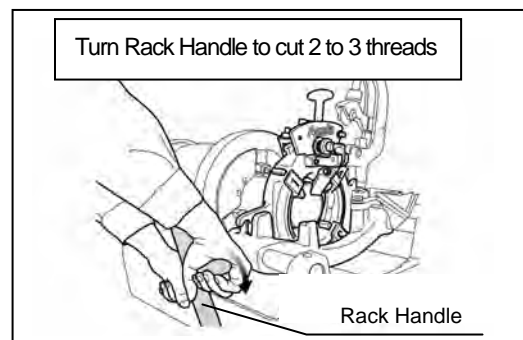

<27>

## ■ For Manual Die-Head

- (1) Lower the Die-Head and throw the Open-Close Lever down toward you.
  - (2) Turn the switch ON, turn the Rack Handle clockwise with pressing Dies to the work piece.
  - (3) Take hands off from the Rack Handle after two or three threads were cut.
  - (4) When the required number of threads have been cut throw the Open-Close Lever up gradually to finish cutting by gradually opening the Dies.
- ※ Should the Dies be opened abruptly, steps may be produced in the finishing section of the thread, resulting in a defective thread.

# BEAVER 50

## 7-1) Adjustment of Thread Length

• The thread length has been adjusted within the standard length at the factory, but can be adjusted as required.

### ■ For Beaver Die-Head 1/2"-2"AT

- (1) Pull the Locking Lever toward A to open Die-Head. (fig.28)
- (2) Loosen Lock Nut and turn Adjust Screw clockwise depending on the required thread length.  
Right turning makes the thread length longer and left turning makes it shorter.  
The thread length will be adjusted about 2.5mm by one rotation. (fig.29)
- (3) After adjustment, tighten Lock Nut.

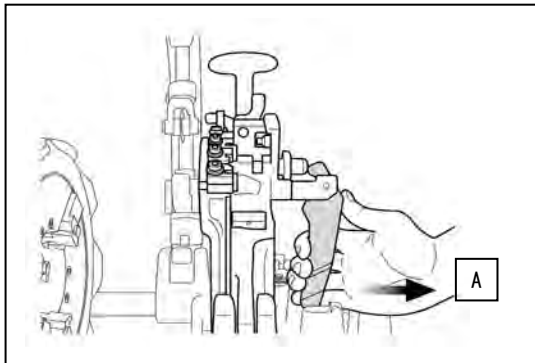

(28)

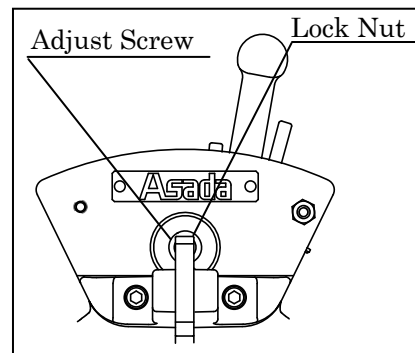

(29)

### ■ For Beaver Die-Head 1/2"-2"

- (1) Hold set pin with a slot screwdriver and loosen hex nut. (fig.30)
- (2) Turning set pin toward "E", makes shorter threads and turning toward "F" makes longer threads.  
The thread length will be changed about 2mm by half turn. (fig.31)
- (3) Hold set pin with a slot screwdriver not to turn it and tighten hex nut.

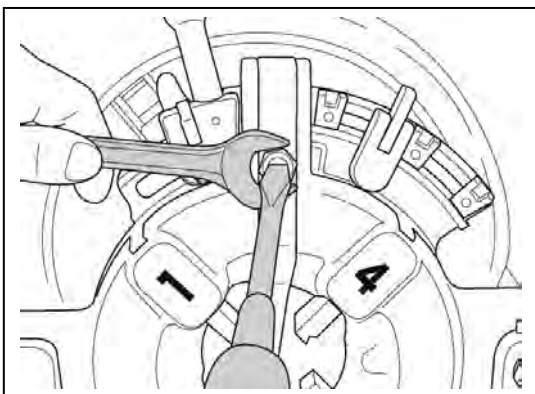

(30)

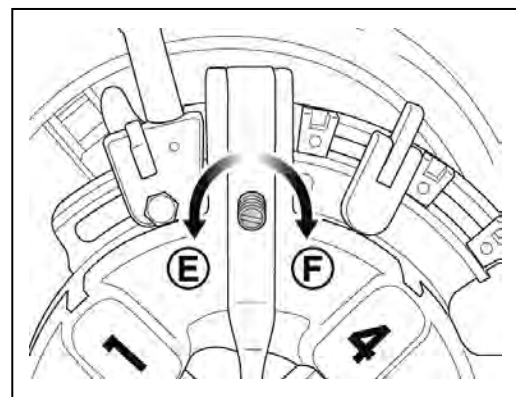

(31)

## 7-2) Adjustment of Thread Depth

### ■ For Beaver Die-Head 1/2"-2"AT

- (1) Loosen the Block Screw securing the Selector Block to the Cam Plate.
- (2) Move the Selector Block to adjust the thread depth. Sliding toward H makes deeper threads and G makes, shallower threads. The thread depth will change by 1.5 to 2 threads under or over by one scale. (fig.32)
- (3) Tighten the Block Screw to secure Selector Block and start threading.
- (4) Check the cut pipe with a Taper Thread Gauge ,etc. and adjust it again if necessary.



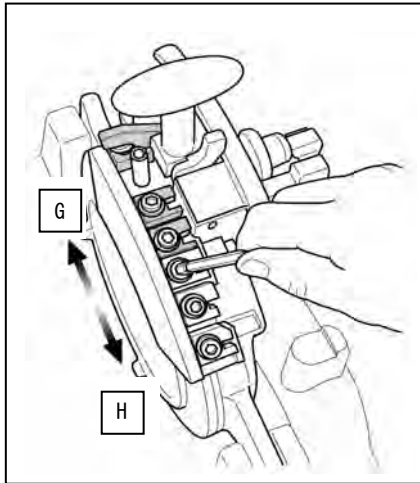

(32)

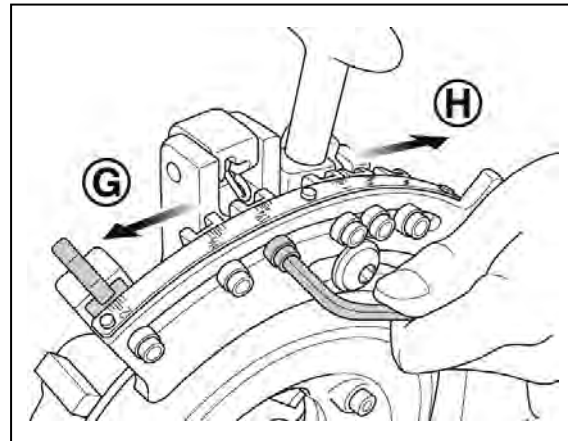

(33)

## ■ For Beaver Die-Head 1/2"-2"

- (1) Set location plate to location block which is not for the size to be adjusted.
- (2) Loosen the screw and move location block to adjust the thread depth.
- (3) Sliding toward "H" makes deeper threads and sliding toward "G" makes shallower threads. The thread depth will change 1.5 to 2 mm threads by one scale. (fig.33)
- (4) With the aid of a measuring instrument, check the cut pipe for a tapered thread etc. and correct the setting if necessary.

## 8) Removing the Work piece

### ▲ CAUTION



- The work piece is wet and slippery with threading oil. Use utmost care not to drop on your feet.

- (1) Turn the Rack Handle counterclockwise and return the Carriage.
- (2) Loosen the Hammer Chuck.
- (3) Loosen the Scroll and pull out the work piece.

## 9) Cleaning after Use

### ▲ CAUTION



- Do not blow off chips using air. They may get into eyes and loss of eyesight may result.



- Chips are sharp. Do not touch them with bare hand. Always wear gloves.

- \* Remove chips scattered on the machine or in the area.
- \* Use a wire brush and clean and remove chips from the Chuck, Dies of Die-Head and Reamer.
- \* Use waste cloth and wipe off the threading oil splashed over the machine and the area.

## 5. MAINTENANCE & INSPECTION

### ⚠ CAUTION



- Always wear gloves when replacing the Cutting Blade and Threading Dies.



- Disconnect the Power Plug.

### 1) Replacement of Parts

#### 1-1) Replacement of Switch

### ⚠ WARNING



- Disconnect the Power Plug to avoid electric shock.

- (1) Remove the four screws, and pull out the switch plate on the front.
- (2) Remove the two screws, and remove the switch from the switch plate.
- (3) Loosen the four screws, and remove the four lead wires to the Switch.
- (4) Install the lead line to a new switch.
- (5) Install a new switch, installed to lead line in the Switch Plate with the two screws.
- (6) Install the Switch Plate in the machine with the four screws.

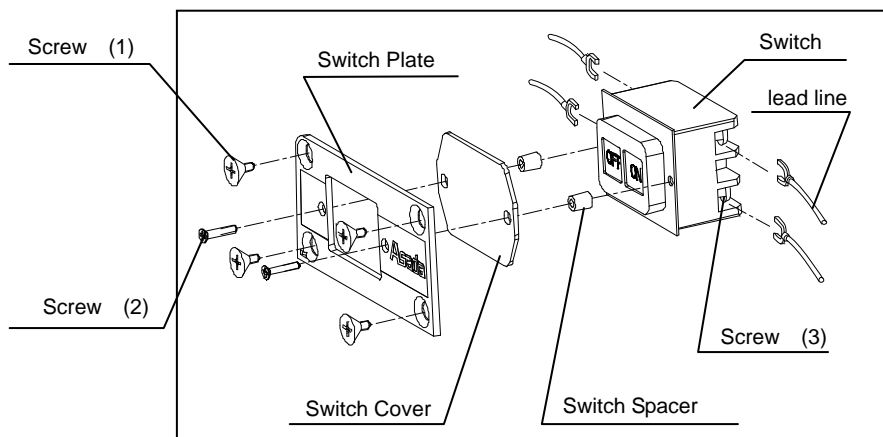

(34)

## 1-2) Replacement of Reamer Blade

### CAUTION



• Wear gloves when working so as not to cut fingers with the Reamer Blade.

- (1) Lift the Cutter and Die-Head and pull the Reamer toward you.
- (2) Put out the Spring Pin in the neck of the Reamer Blade.
- (3) The Reamer Blade is detached by pulling the Reamer Holder forward.
- (4) Install a new Reamer Blade.
- (5) Re-insert the removed Spring Pin in the hole of a new Reamer Blade.

## 1-3) Replacement of Cutter Blade

- (1) Swing the Cutter to upright position and lower the Die-Head.
- (2) Straighten the bend of split pin and pull it upward. (fig.35)
- (3) While holding the Blade, slightly push out the Cutter Blade Set Pin and pull out from the opposite side. (fig.36)

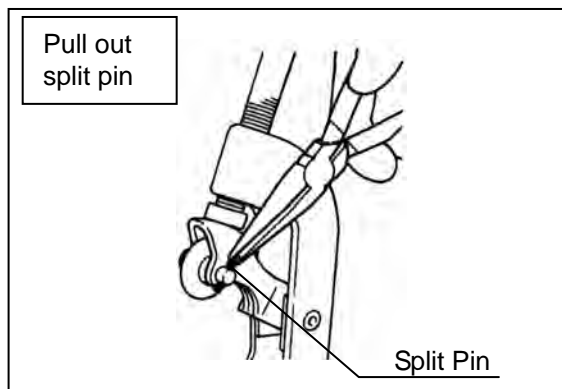

<35>

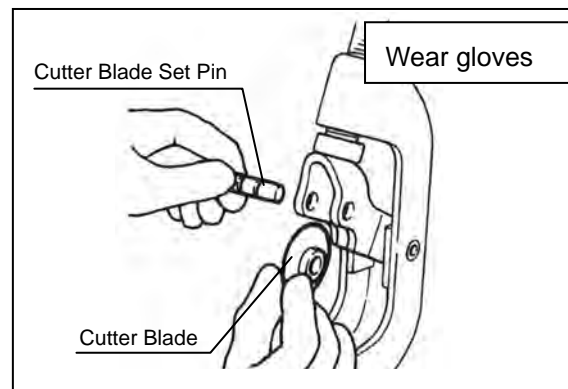

<36>

- (4) Wipe off chips, dirt, oil, etc. from the pin and apply grease to the groove.
- (5) Put a new Blade into the Blade Bracket and insert pin.
- (6) Insert a new split pin into the Cutter Blade Set Pin, and end the ends.

# BEAVER 50

## 1-4) Replacement of Pump

### CAUTION



• Oil in the pump and tube overflows, staining the floor. Spread waste cloth around the Pump.



• Be careful not to place the code by the motor cover when you assemble the motor cover. Damaged cord and current leakage will occur.

- (1) Set an oil pan (2.2 liters), remove the drain plug to drain the oil.
- (2) Turn the Pump Cover mounting bolts and remove the Pump Cover from this machine. (fig37)
- (3) Turn the Pump mounting bolts and remove the Pump from this machine. (fig38)

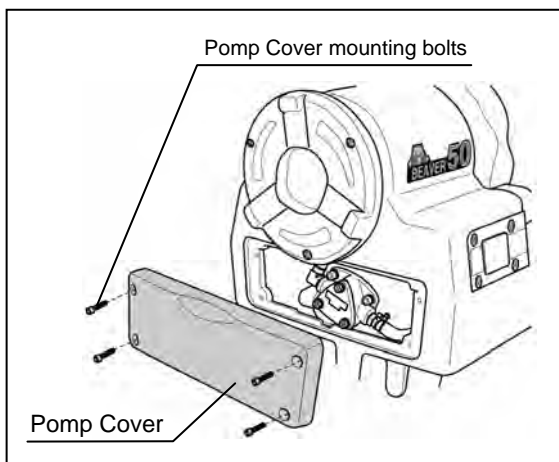

<37>

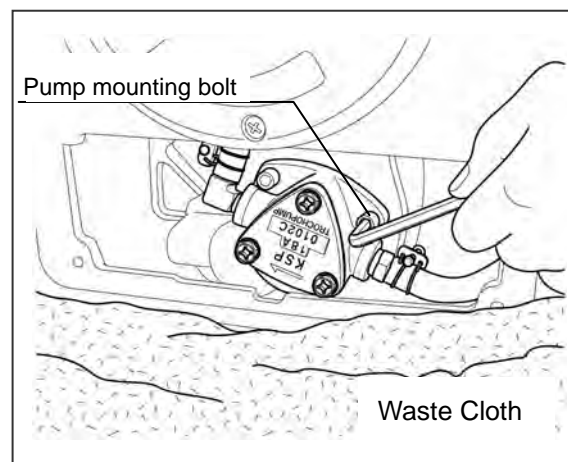

<38>

- (4) Loosen the hose band and remove the hose from the Pump. Pay attention to the overflowing oil. (fig39)
- (5) Install a new Pump to two hoses and firmly tighten the Hose Band.
- (6) Turn the Pump Shaft, set it to the groove on the machine side and install the Pump with the removed bolts. (fig.40)

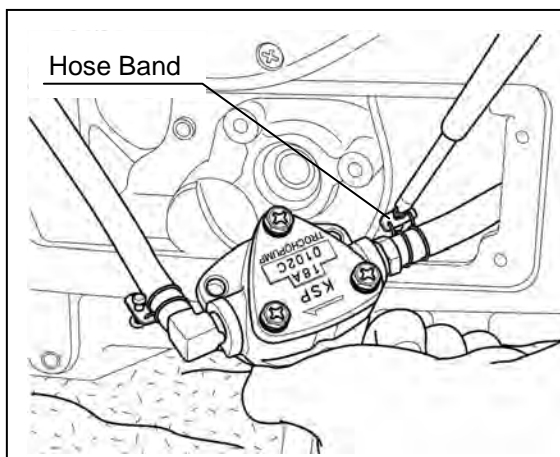

<39>

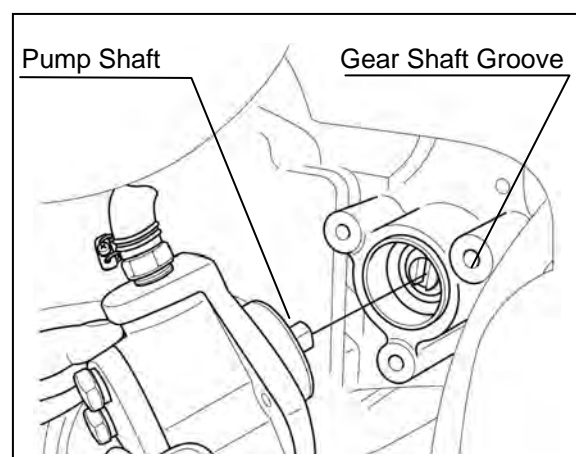

<40>

- (7) Install the Pump Cover with the removed bolts. In that case, be careful not to place the code of the Motor by the Pump Cover.
- (8) Fill threading oil (2.2 liters) and lower the Die Head.
- (9) Turn ON the switch and ensure the oil flows out from the Die Head.

## 1-5) Replacement of Jaw Inserts

### ⚠ CAUTION



• Disconnect the Power Plug.

- (1) Turn the Rack Handle counterclockwise so that the Carriage moves to the right end.
- (2) Swing the Cutter upward to out-of-way position.
- (3) Turn the Hammer Chuck and open up to until the Screwdriver enters. (fig41)
- (4) Loosen the screws securing the Jaw Inserts. (fig42)

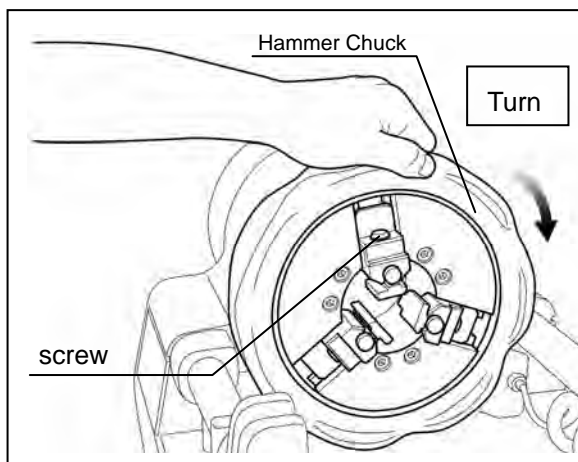

<41>

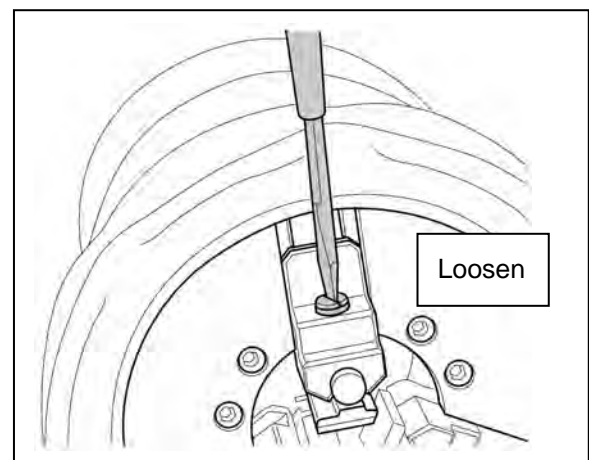

<42>

- (5) Place a thin stick on the edge of the spring and pull out Spring(2) and the Chuck Pin. (fig43)
- (6) Pull the Jaw Insert forward. (fig44)
- (7) If three Jaw Inserts are to be replaced at the same time. Remove the other two Jaw Inserts.

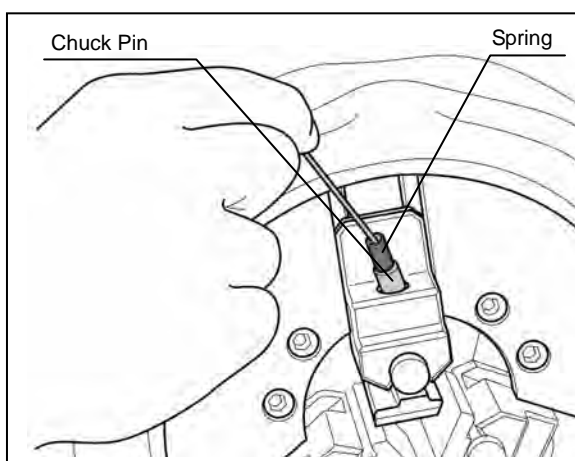

<43>

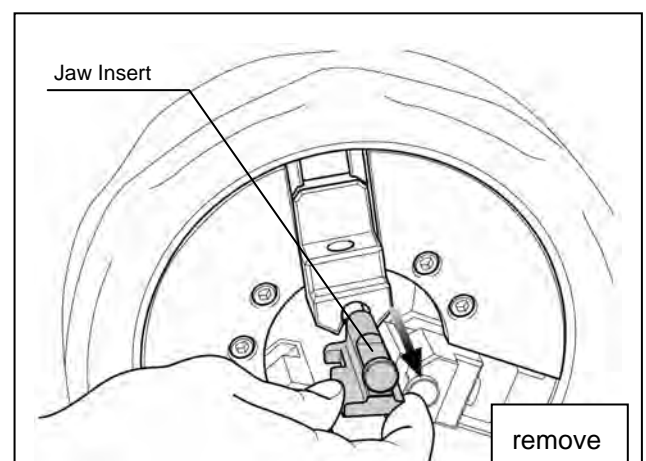

<44>

- (8) Wipe off chips, dirt, oil, etc. from the Jaw Insert mounting surface.
- (9) Insert a new Jaw Insert up to the back and replace the Spring(2) and the Chuck Pin. Firmly tighten the screw.
- (10) Install other two Jaw Inserts in the same manner.

# BEAVER 50

## 1-6) Replacement of Carbon Brush

### ⚠ WARNING



- Disconnect the Power Plug to avoid electric shock.

### ⚠ CAUTION



- Keep the new carbon brush free from oil, dirt, chips, etc. Avoid the stain of gloves from attaching to the Carbon Brush.
- A replacement opening is provided on the bottom of this machine. Erect the machine using utmost care not to fall.

- (1) Drain oil.
- (2) Remove the Die-Head and lay down the machine.
- (3) Unscrew the Under Cover mounting bolts and remove the Under Cover from the machine. (fig45)
- (4) Turn the cap inside with a flat screwdriver and take out the Carbon Brush. (fig46,47)

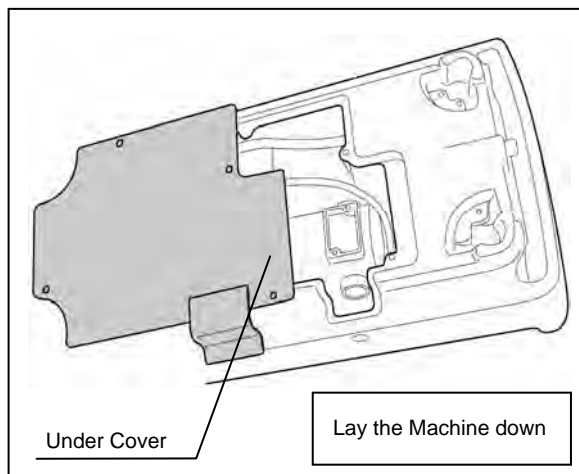

<45>

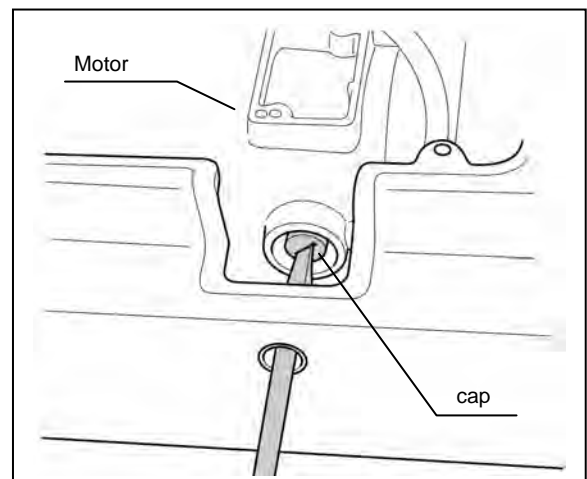

<46>

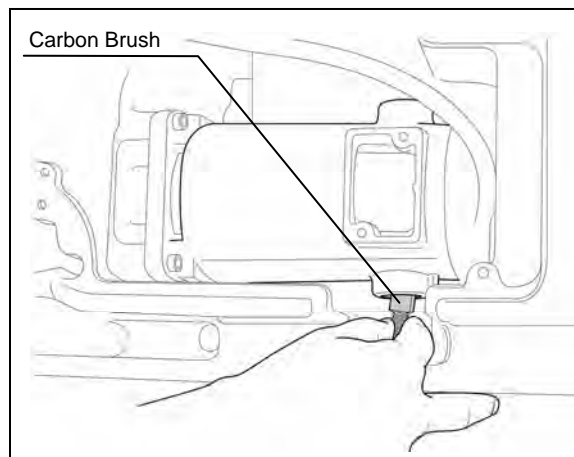

<47>

- (5) Insert a new Carbon Brush. Do not stain the Carbon Brush with oil on fingers, etc.
- (6) Install the cap and install the Under Cover with the removed bolts.

## 2) Adjustment of Parts

### 2-1) Adjustment of Amount of Discharging Thread Oil

- (1) Ensure the oil is filled into the tank up to the Strainer wire netting.
- (2) If the amount of threading oil discharged from the Die-Head is not appropriate, adjust the discharging amount with the Oil Adjust Screw.
- (3) Loosen the lock nut of the Oil Adjust Screw.
- (4) Turning the Oil Adjust Screw clockwise increases the amount of oil and counterclockwise turn decreases the amount of oil. (fig.48)

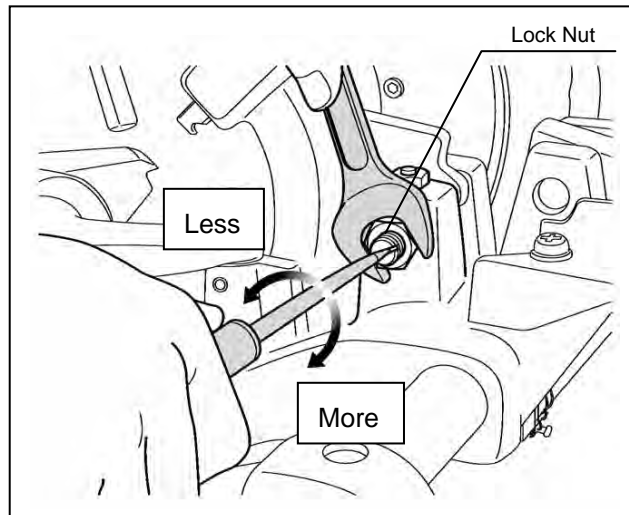

〈48〉

- (5) Tighten the lock nut after adjustment.

# BEAVER 50

## 3) Daily Inspection and Maintenance

### ⚠ CAUTION



• Do not wet the motor with water or oil.

- \* Immediately replace Power Plug, Power Cord and extension cord, if damage.
- \* Ensure the oil is filled up to the tank lid wire netting. If not, replenish.



- \* Adjust with the Oil Adjust Screw if the amount of threading oil discharged from the Die-Head is not appropriate.
- \* Contamination in the tank causes pump failure. Clean the tank on a periodic basis.
- \* Check the Dies, Cutter and Reamer Blade for chipping. Replace if chipped.

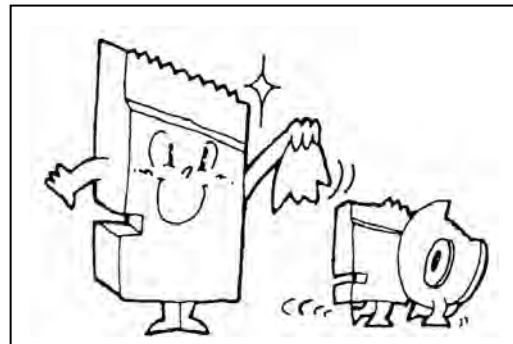

- \* Clogged chuck jaws cause improper chucking. Clean with wire brush.



- \* Check for loose fitting screws of parts. If used loosened, danger can result. Retighten them.
- \* Completely wipe off dirt and chips from the machine.
- \* Coat the machine with rust preventive grease when the machine is not used for a long period of time.



## 6. Before asking for Repairs

### 1) In case the oil does not come out:

- \* Is the Oil Tank full of oil?
- \* Are the Suction Pipe , the Strainer and the Filter clear ?
- \* Is the Pump in order ?

### 2) In case power is not enough:

- \* Has the power voltage not dropped ?
- \* Is the extension cord not too long or slim ?

### 3) In case threads are not normal:

- \* Is the threading oil not contaminated or dirty ?
- \* Are there chipping of the Dies ?
- \* Is the cut end or the pipe not oblique ?

### 4) In case threading fails:

- \* Is the Dies size correct ?
- \* Do Die numbers agree with those on Die-Head ?
- \* Is the size selection of Die-Head correct ?

## 7. ELECTRICAL WIRING DIAGRAM

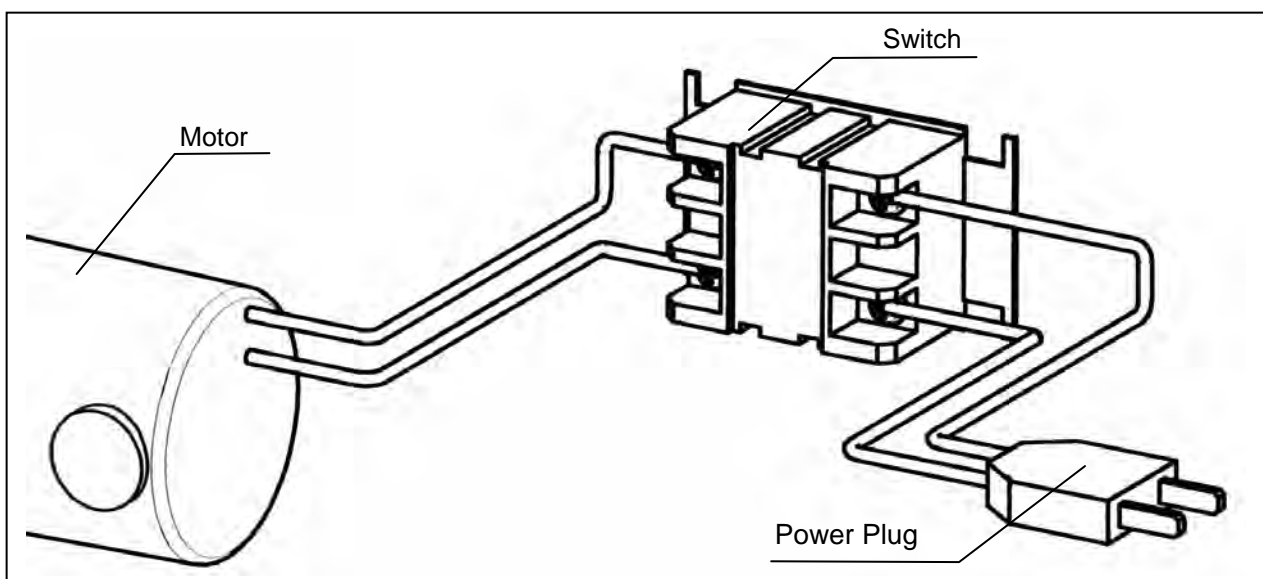





## CUSTOMER NOTE

Please enter the following use. This note will be useful in making inquiries and placing purchase orders for parts.

**SERIAL No.:**

**DATE OF PURCHASE:**

**SALES REPRESENTATIVE:**

**Asada**  
ASADA CORPORATION

3-60, Kamiida, Nishi-Machi, Kita-Ku, Nagoya, Japan 462-8551  
TEL +81-52-914-1062  
URL <http://www.asada.co.jp>

FAX +81-52-914-1065  
E-mail: [trade@asada.co.jp](mailto:trade@asada.co.jp)

Code No. BE605  
Ver. 04 A